

# Implications of Recent Measurements in Neutrino Sector & Future Directions

---

**Sanjib Kumar Agarwalla**

*sanjib@iopb.res.in*

**Institute of Physics, Bhubaneswar, India**



# The Standard Model: Massless Neutrinos

The Standard Model is a gauge theory & it unifies strong, weak & electromagnetic forces!

$$SU(3)_C \times SU(2)_L \times U(1)_Y \Rightarrow SU(3)_C \times U(1)_{EM}$$

$(1, 2)_{-\frac{1}{2}}$	$(3, 2)_{\frac{1}{6}}$	$(1, 1)_{-1}$	$(3, 1)_{\frac{2}{3}}$	$(3, 1)_{-\frac{1}{3}}$
$\begin{pmatrix} \nu_e \\ e \end{pmatrix}_L$	$\begin{pmatrix} u^i \\ d^i \end{pmatrix}_L$	$e_R$	$u^i_R$	$d^i_R$
$\begin{pmatrix} \nu_\mu \\ \mu \end{pmatrix}_L$	$\begin{pmatrix} c^i \\ s^i \end{pmatrix}_L$	$\mu_R$	$c^i_R$	$s^i_R$
$\begin{pmatrix} \nu_\tau \\ \tau \end{pmatrix}_L$	$\begin{pmatrix} t^i \\ b^i \end{pmatrix}_L$	$\tau_R$	$t^i_R$	$b^i_R$

3-fold repetition of the same representation!

- 3 *active* neutrinos:  $\nu_e, \nu_\mu, \nu_\tau$
- Neutral elementary particles of Spin  $\frac{1}{2}$
- Only couple to *weak force* (& gravity)
- Only *left handed* neutrinos
- There are no right-handed neutrinos
- No Dirac Mass term:  $m(\bar{\psi}_L\psi_R + \bar{\psi}_R\psi_L)$

**Neutrinos are massless in the Basic SM!**

- ❑ Over the past decade, marvelous data from world class neutrino experiments firmly established that they change flavor after propagating a finite distance!
- ❑ Neutrino flavor change (oscillation) demands non-zero mass and mixing!

**Non-zero  $\nu$  mass: first experimental proof for physics beyond the Standard Model!**

**!! An extension of the Standard Model is necessary !!**

# Neutrino Physics: An Exercise in Patience

The three most fundamental questions were formulated in the past century...

## 1. How tiny is the neutrino mass? (Pauli, Fermi, '30s)

Recent Planck satellite data set an upper limit of **0.23 eV** for the sum of neutrino masses!

Planck Collaboration, arXiv:1303.5076 [astro-ph.CO]

## 2. Can a neutrino turn into its own antiparticle? (Majorana, '30s)

Hunt for  $\nu$ -less Double- $\beta$  decay ( $Z, A \rightarrow Z+2, A$ ) is still on, demands **lepton number violation!**

Nice Review by Avignone, Elliott, Engel, Rev.Mod.Phys. 80 (2008) 481-516

## 3. Do different $\nu$ flavors 'oscillate' into one another? (Pontecorvo, Maki-Nakagawa-Sakata, '60s)

B. Pontecorvo, Sov. Phys. JETP 26, 984 (1968) [Zh. Eksp. Teor. Fiz. 53, 1717 (1967)]

The last question has been positively answered only in recent years. It is now an established fact that **neutrinos are massive** and leptonic flavors are not **symmetries of Nature!**

With the recent measurement of the **last unknown mixing angle  $\theta_{13}$** , a clear first order picture of the 3-flavor lepton mixing matrix has emerged, signifies a major breakthrough in  $\nu$  physics!

The year 2013 marks the **100<sup>th</sup> anniversary** of the birth of Pontecorvo, a great tribute to him!

# Neutrino Oscillations in 3 Flavors

$\nu$  oscillation is a quantum mechanical phenomenon like electrons in the double slit experiment!  
It happens because flavor (weak) eigenstates do not coincide with mass eigenstates

Flavor States:  $\nu_e, \nu_\mu, \nu_\tau$  (produced in weak interactions)

Mass States:  $\nu_1, \nu_2, \nu_3$  (propagate from source to detector)

$$|\nu_\alpha\rangle = \sum_{i=1}^3 U_{\alpha i}^* |\nu_i\rangle \quad (\alpha = e, \mu, \tau)$$

$$U = \begin{pmatrix} 1 & 0 & 0 \\ 0 & c_{23} & s_{23} \\ 0 & -s_{23} & c_{23} \end{pmatrix} \begin{pmatrix} c_{13} & 0 & s_{13}e^{-i\delta} \\ 0 & 1 & 0 \\ -s_{13}e^{i\delta} & 0 & c_{13} \end{pmatrix} \begin{pmatrix} c_{21} & s_{12} & 0 \\ -s_{12} & c_{12} & 0 \\ 0 & 0 & 1 \end{pmatrix}$$

↔ atmospheric sector
↔ connection between solar and atmospheric
↔ solar sector

$c_{ij} = \cos\theta_{ij}$  and  $s_{ij} = \sin\theta_{ij}$

U is a 3×3 unitary matrix containing  $\theta_{23}, \theta_{13}, \theta_{12}$  and one CP violating (Dirac) phase  $\delta_{CP}$

3 mixing angles simply related to flavor components of 3 mass eigenstates

$$\tan^2 \theta_{12} \equiv \frac{|U_{e2}|^2}{|U_{e1}|^2}; \quad \tan^2 \theta_{23} \equiv \frac{|U_{\mu 3}|^2}{|U_{\tau 3}|^2}; \quad U_{e3} \equiv \sin \theta_{13} e^{-i\delta}$$

Over a distance L, changes in the relative phases of the mass states may induce flavor change!

$$P(\nu_\alpha \rightarrow \nu_\beta) = \delta_{\alpha\beta} - 4 \sum_{i>j} \text{Re}[U_{\alpha i}^* U_{\alpha j} U_{\beta i} U_{\beta j}^*] \sin^2 \Delta_{ij} - 2 \sum_{i>j} \text{Im}[U_{\alpha i}^* U_{\alpha j} U_{\beta i} U_{\beta j}^*] \sin 2\Delta_{ij}$$

$$\Delta_{ij} = \Delta m_{ij}^2 L / 4E_\nu$$

$$\Delta m_{ij}^2 = m_i^2 - m_j^2$$

2 independent mass splittings  $\Delta m_{21}^2$  and  $\Delta m_{32}^2$ , for anti-neutrinos replace U by  $U^*$

# Neutrino Oscillations in Matter

Neutrino propagation through matter can modify the oscillations significantly!

There is **coherent forward elastic** scattering of neutrinos with matter particles!

Can be compared with the visible light travelling through glass!

Charged current interaction of  $\nu_e$  with electrons creates an **extra potential for  $\nu_e$** !

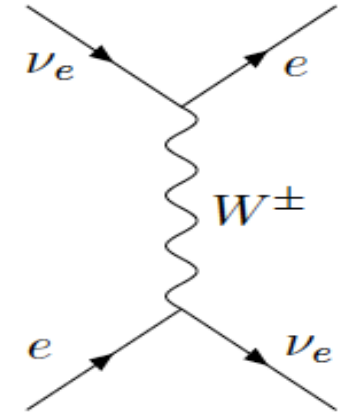

Wolfenstein matter term:  $A = \pm 2\sqrt{2}G_F N_e E$  or  $A(\text{eV}^2) = 0.76 \times 10^{-4} \rho (\text{g/cc}) E(\text{GeV})$

$N_e$  = electron number density, + (-) for **neutrinos (anti-neutrinos)**,  $\rho$  = matter density in Earth

**Matter term changes sign when we switch from neutrino mode to anti-neutrino mode!**

$P(\nu_\alpha \rightarrow \nu_\beta) - P(\bar{\nu}_\alpha \rightarrow \bar{\nu}_\beta) \neq 0 \implies$  even if  $\delta_{CP} = 0$ , causes fake CP asymmetry!

**Matter term modifies oscillation probability differently depending on the sign of  $\Delta m^2$**

$\Delta m^2 \simeq A \iff E_{\text{res}}^{\text{Earth}} = 6 - 8 \text{ GeV} \implies$  Resonant conversion – the MSW effect

	$\nu$	$\bar{\nu}$
$\Delta m^2 > 0$	MSW	-
$\Delta m^2 < 0$	-	MSW



Resonance occurs for **neutrinos (anti-neutrinos)** if  $\Delta m^2$  is **positive (negative)**

# The $\theta_{13}$ Revolution

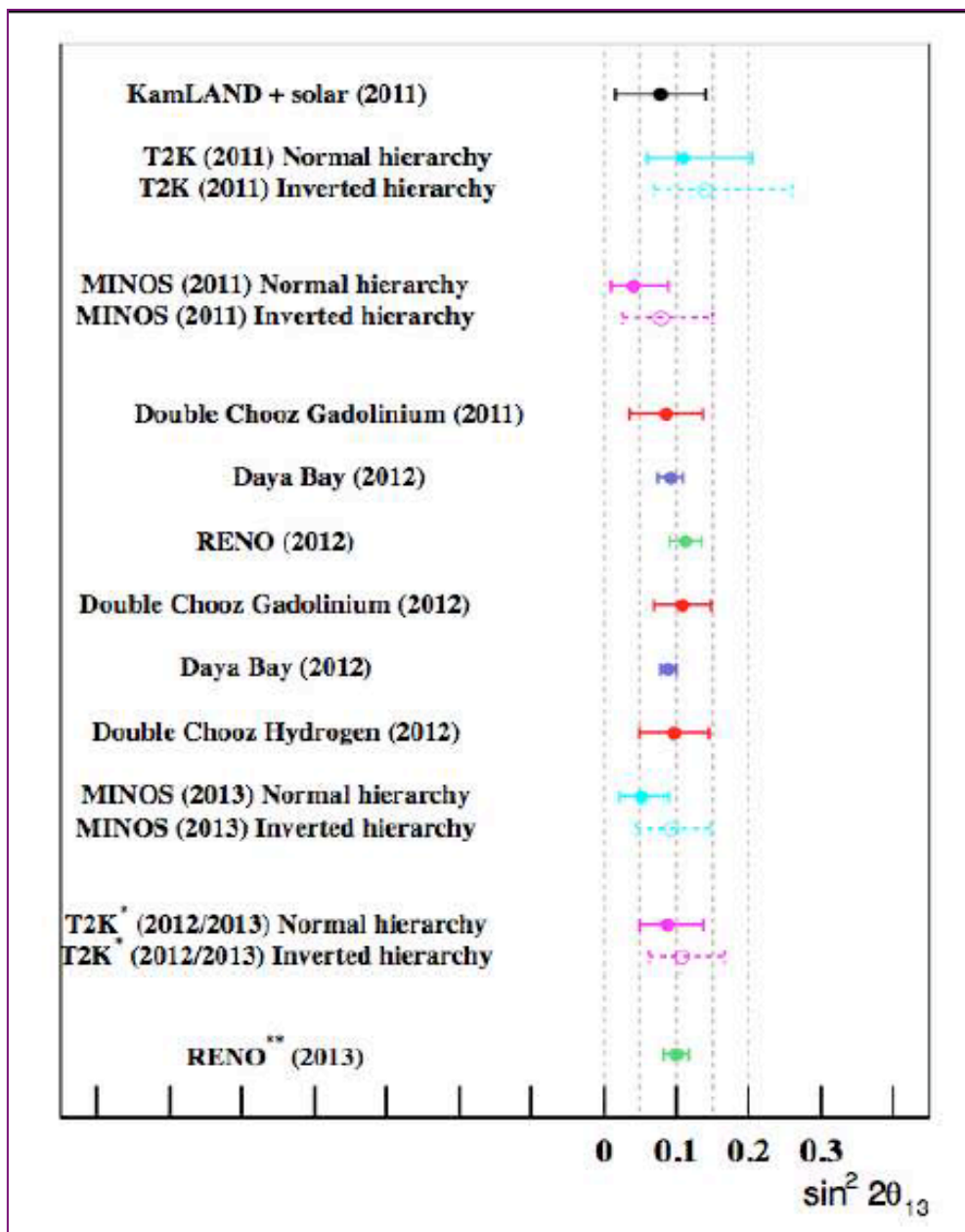

## Big News: Discovery of $\theta_{13}$

- ★ Several results from reactor and accelerator experiments!
- ★ Some single results exceed  $5\sigma$  significance for non-zero  $\theta_{13}$ !
- ★ All results agree well!
- ★ Combining all the data, more than  $10\sigma$  confirmation of non-zero  $\theta_{13}$ !
- ★ Relative  $1\sigma$  precision of 10% achieved!
- ★ Note that: 2 years ago, we had only  $2\sigma$  indications!

## Present Status of Neutrino Parameters

	bfp $\pm 1\sigma$	$3\sigma$ range	Relative $1\sigma$ Precision
$\sin^2 \theta_{12}$	$0.30 \pm 0.013$	$0.27 \rightarrow 0.34$	
$\theta_{12}/^\circ$	$33.3 \pm 0.8$	$31 \rightarrow 36$	(3.9%)
$\sin^2 \theta_{23}$	$0.41^{+0.037}_{-0.025} \oplus 0.59^{+0.021}_{-0.022}$	$0.34 \rightarrow 0.67$	(11%)
$\theta_{23}/^\circ$	$40.0^{+2.1}_{-1.5} \oplus 50.4^{+1.2}_{-1.3}$	$36 \rightarrow 55$	
$\sin^2 \theta_{13}$	$0.023 \pm 0.0023$	$0.016 \rightarrow 0.030$	(10%)
$\theta_{13}/^\circ$	$8.6^{+0.44}_{-0.46}$	$7.2 \rightarrow 9.5$	
$\delta_{CP}/^\circ$	$300^{+66}_{-138}$	$0 \rightarrow 360$	(Not Known)
$\frac{\Delta m_{21}^2}{10^{-5} \text{ eV}^2}$	$7.50 \pm 0.185$	$7.00 \rightarrow 8.09$	(2.4%)
$\frac{\Delta m_{31}^2}{10^{-3} \text{ eV}^2}$ (N)	$2.47^{+0.069}_{-0.067}$	$2.27 \rightarrow 2.69$	(2.8%)
$\frac{\Delta m_{32}^2}{10^{-3} \text{ eV}^2}$ (I)	$-2.43^{+0.042}_{-0.065}$	$-2.65 \rightarrow -2.24$	

Gonzalez-Garcia, Maltoni, Salvado, Schwetz, JHEP 1212 (2012) 123

$\theta_{13}$  has been determined to be reasonably large, not too far from its previous upper bound!

Indication of non-maximal 2-3 mixing angle ( $\sim 2\sigma$ ) by the MINOS accelerator experiment!

# The Two Fundamental Questions

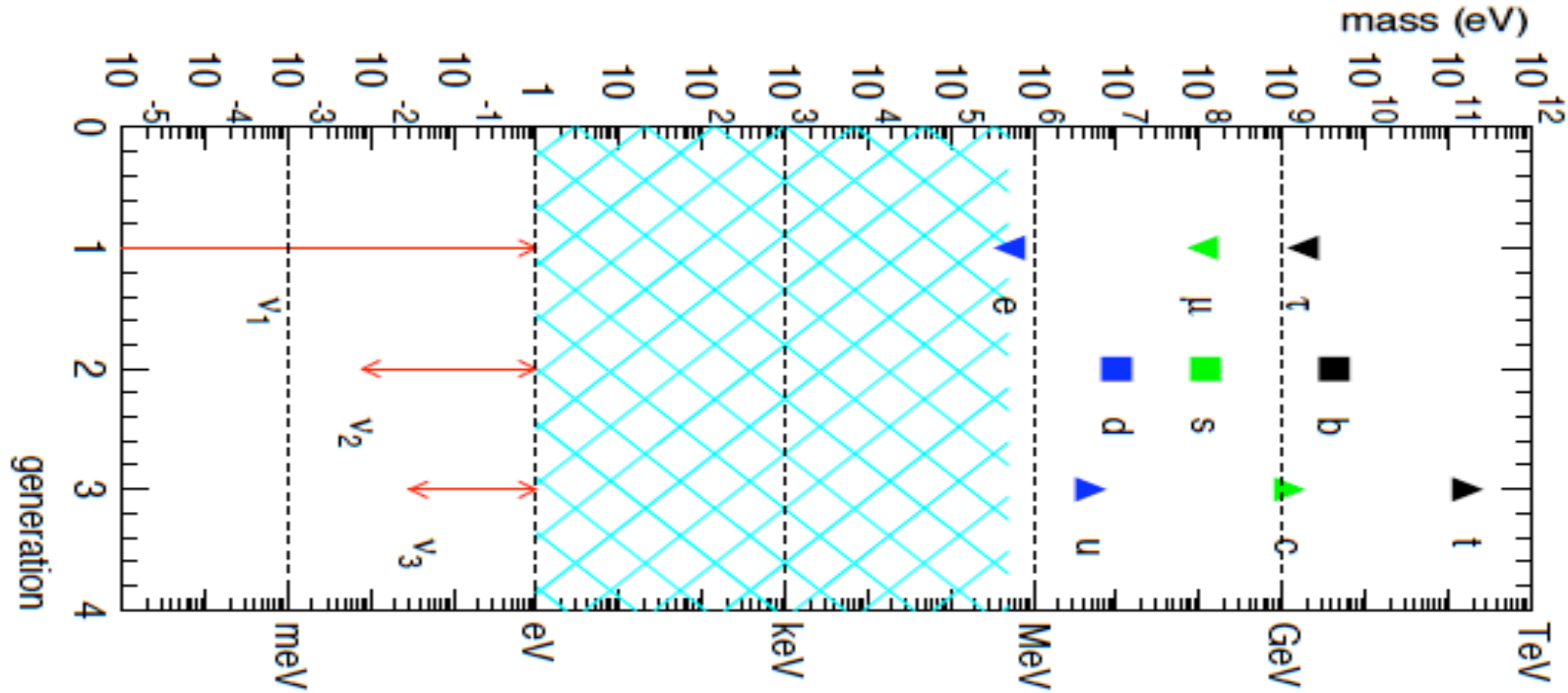

**Why are neutrinos so light? The origin of Neutrino Mass!**

	Neutrinos (PMNS)	Quarks (CKM)
$\theta_{12}$	$35^\circ$	$13^\circ$
$\theta_{32}$	$43^\circ$	$2^\circ$
$\theta_{13}$	$9^\circ$	$0.2^\circ$
$\delta$	unknown	$68^\circ$

**Why are lepton mixings so different from quark mixings?**

**The Flavor Puzzle!**



# Latest Results on $\theta_{13}$ : What happened to Mass models?

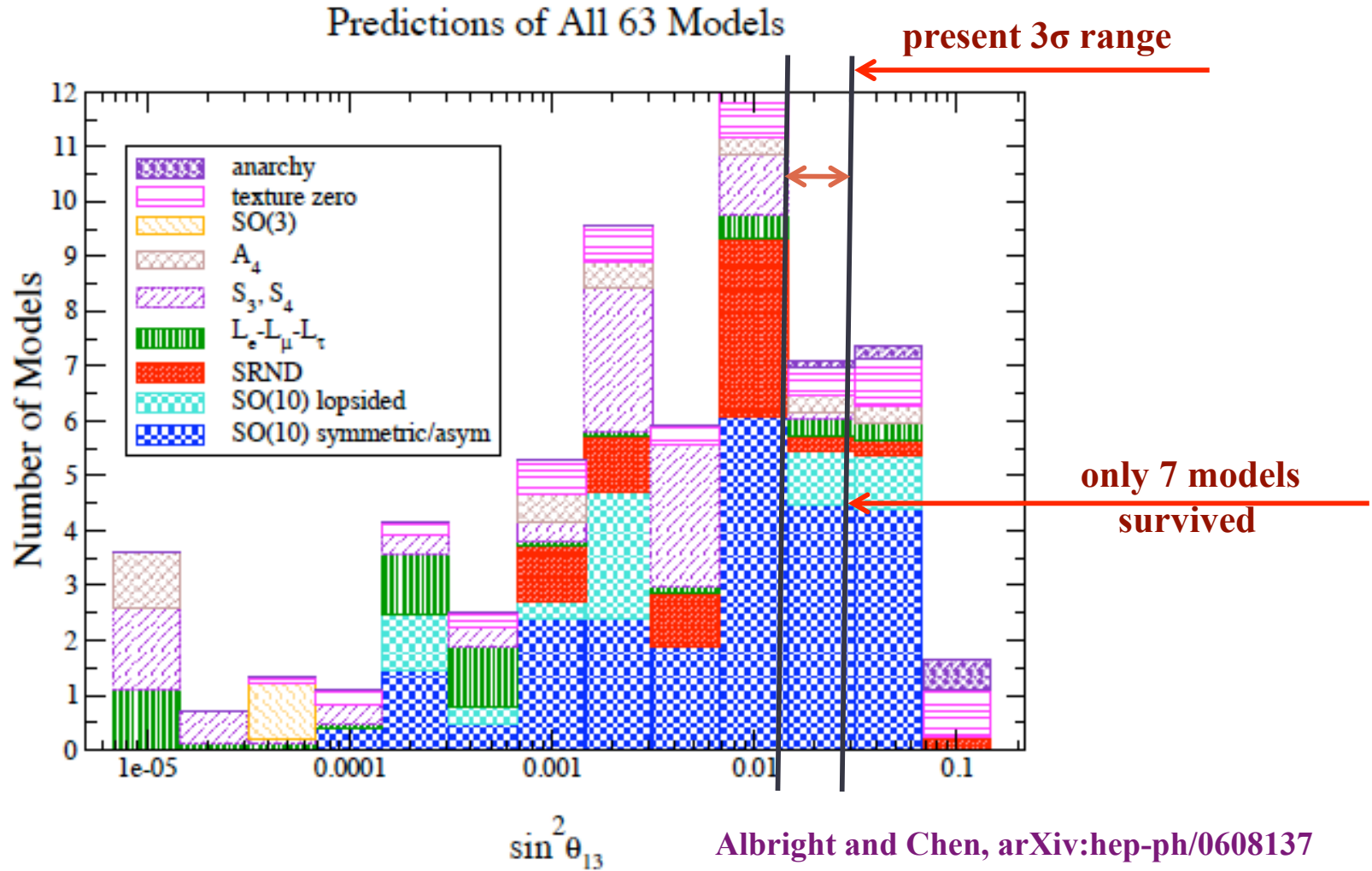

Survey of 63 neutrino mass models in June 2006 by Carl H. Albright and Mu-Chun Chen!

Future high precision measurements of mixing angles, new information on neutrino mass ordering and CP phase will severely constrain these presently allowed models!

# Implications of Recent Measurement of $\theta_{13}$

## Simplest models that are ruled out!

- **Bimaximal mixing:** [Vissani (97), Barger, Pakvasa, Weiler, Whisnant (98)]

It predicts:  $\theta_{12} = 45^\circ$ ,  $\theta_{23} = 45^\circ$ , and  $\theta_{13} = 0^\circ$

predicted in flavor symmetry models with symmetry groups like A4, S4, A5

- **Tri-bimaximal mixing:** [Vissani (97), Harrison, Perkins, Scot (02)]

$$U_{\text{TBM}} = R_{32} \left( \theta_{32} = \frac{\pi}{4} \right) R_{13}(\theta_{13} = 0) R \left( \theta_{21} = \tan^{-1} \left( \frac{1}{\sqrt{2}} \right) \right) = \frac{1}{\sqrt{6}} \begin{pmatrix} 2 & \sqrt{2} & 0 \\ -1 & \sqrt{2} & \sqrt{3} \\ 1 & -\sqrt{2} & \sqrt{3} \end{pmatrix}$$

- **Golden ratio:** [Datta, Ling, Ramond (03), Kajiyama, Raidal, Strumia (07)]

It predicts:  $\theta_{12} = 31.7^\circ$ ,  $\theta_{23} = 45^\circ$ , and  $\theta_{13} = 0^\circ$

## Simplest models that are still alive!

- **Anarchy ( $\nu$  mass matrix completely random):** [Hal, Murayama, Weiner (99), de Gouvea, Murayama (03, 12)]

It predicts: large  $\theta_{13}$ , okay with observed value of  $\theta_{13}$

- **Quark-Lepton Complementarity:** [Minakata, Smirnov (94), Raidal (04)]

Based on observation:  $\theta_{12}(\text{PMNS}) + \theta_{12}(\text{CKM}) = 45^\circ$

It predicts:  $\sin\theta_{13} \approx \sin\theta_C / \sqrt{2} \approx 0.16$  (close to the observed value, other relations needs to be tested!)

# Fundamental Unknowns in Neutrino Sector

## 1. What is the hierarchy of the neutrino mass spectrum, normal or inverted?

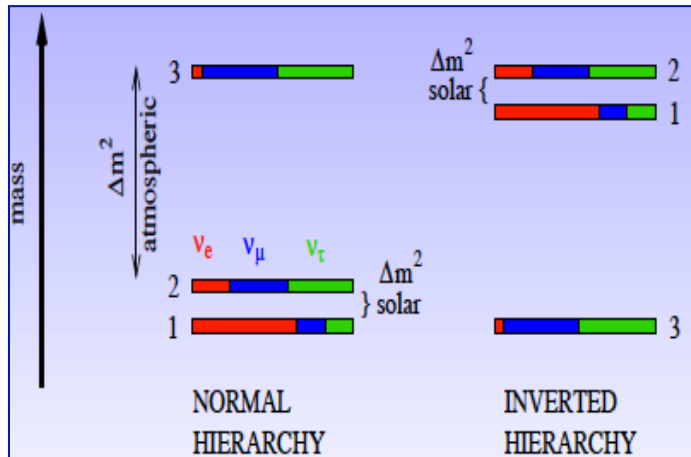

- The sign of  $\Delta m_{31}^2 = m_3^2 - m_1^2$  is not known!
- Currently do not know which neutrino is the heaviest?
- Only have a lower bound on the mass of the heaviest  $\nu$ !

$$\sqrt{2.5 \cdot 10^{-3} \text{eV}^2} \sim 0.05 \text{ eV}$$

## 2. What is the octant of the 2-3 mixing angle, lower ( $\theta_{23} < 45^\circ$ ) or higher ( $\theta_{23} > 45^\circ$ )?

If  $\sin^2 2\theta_{23}$  differs from 1 as indicated by the recent neutrino data, we get two solutions for  $\theta_{23}$ : one  $< 45^\circ$ , termed as lower octant (LO) and the other  $> 45^\circ$ , known as higher octant (HO)

## 2. Is there CP violation in the leptonic sector, as in the quark sector?

Mixing can cause CP violation in the leptonic sector (if  $\delta_{CP}$  differs from  $0^\circ$  and  $180^\circ$ )!

Need to measure the CP-odd asymmetries:  $\Delta P_{\alpha\beta} \equiv P(\nu_\alpha \rightarrow \nu_\beta; L) - P(\bar{\nu}_\alpha \rightarrow \bar{\nu}_\beta; L)$  ( $\alpha \neq \beta$ )

With our current knowledge of  $\theta_{13}$ , resolving these fundamental unknowns fall within our reach! Sub-leading 3 flavor effects are extremely crucial in current and future long baseline experiments!

# Three Flavor Effects in $\nu_\mu \rightarrow \nu_e$ oscillation probability

The appearance probability ( $\nu_\mu \rightarrow \nu_e$ ) in matter, upto second order in the small parameters  $\alpha \equiv \Delta m_{21}^2 / \Delta m_{31}^2$  and  $\sin 2\theta_{13}$ ,

$$\begin{aligned}
 P_{\mu e} \simeq & \underbrace{\sin^2 2\theta_{13}}_{0.09} \underbrace{\sin^2 \theta_{23}}_{0.03} \frac{\sin^2[(1 - \hat{A})\Delta]}{(1 - \hat{A})^2} \longrightarrow \theta_{13} \text{ Driven} \\
 & - \underbrace{\alpha \sin 2\theta_{13}}_{0.009} \xi \sin \delta_{CP} \sin(\Delta) \frac{\sin(\hat{A}\Delta)}{\hat{A}} \frac{\sin[(1 - \hat{A})\Delta]}{(1 - \hat{A})} \longrightarrow \text{CP odd} \\
 & + \alpha \sin 2\theta_{13} \xi \cos \delta_{CP} \cos(\Delta) \frac{\sin(\hat{A}\Delta)}{\hat{A}} \frac{\sin[(1 - \hat{A})\Delta]}{(1 - \hat{A})} \longrightarrow \text{CP even} \\
 & + \underbrace{\alpha^2}_{0.0009} \cos^2 \theta_{23} \sin^2 2\theta_{12} \frac{\sin^2(\hat{A}\Delta)}{\hat{A}^2}; \longrightarrow \text{Solar Term}
 \end{aligned}$$

where  $\Delta \equiv \Delta m_{31}^2 L / (4E)$ ,  $\xi \equiv \cos \theta_{13} \sin 2\theta_{21} \sin 2\theta_{23}$ ,  
and  $\hat{A} \equiv \pm(2\sqrt{2}G_F n_e E) / \Delta m_{31}^2$

changes sign with  $\text{sgn}(\Delta m_{31}^2)$   
key to resolve hierarchy!

changes sign with polarity  
causes fake CP asymmetry!

Cervera et al., hep-ph/0002108

Freund et al., hep-ph/0105071

See also, Agarwalla et al., arXiv:1302.6773 [hep-ph]

**This channel suffers from: (Hierarchy –  $\delta_{CP}$ ) & (Octant –  $\delta_{CP}$ ) degeneracy! How can we break them?**

# Hierarchy – $\delta_{CP}$ degeneracy in $\nu_\mu \rightarrow \nu_e$ oscillation channel

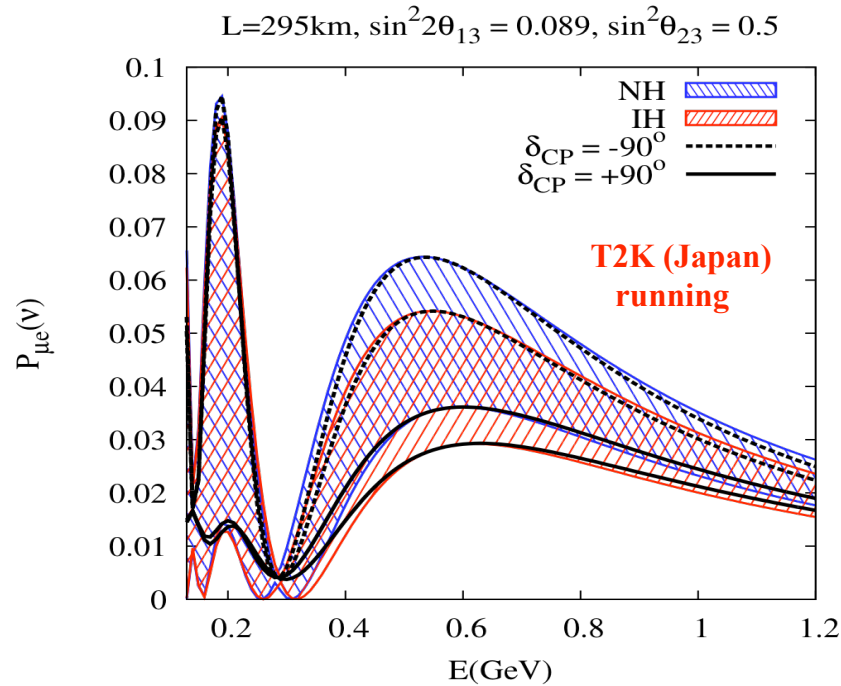

For  $\nu$ :  
Max: NH,  $-90^\circ$   
Min: IH,  $90^\circ$

Degeneracy pattern  
different between  
T2K & NOvA

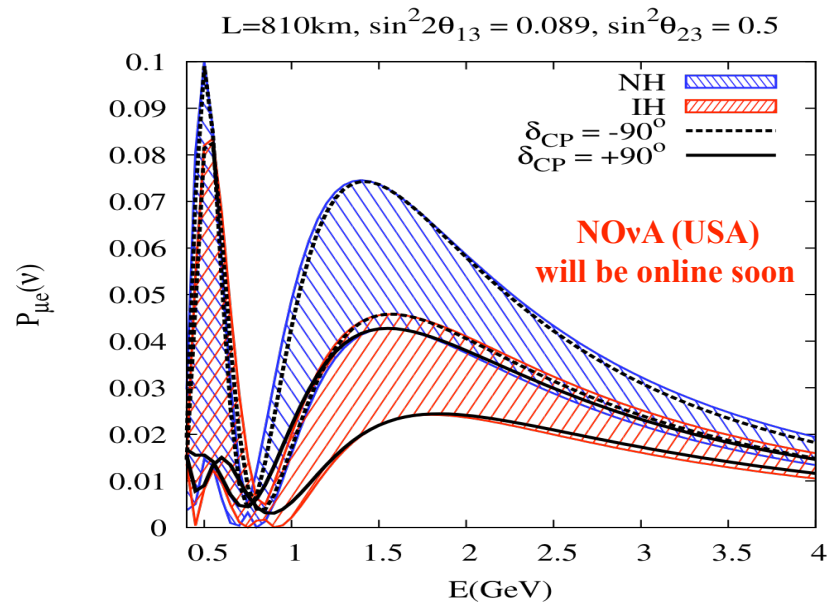
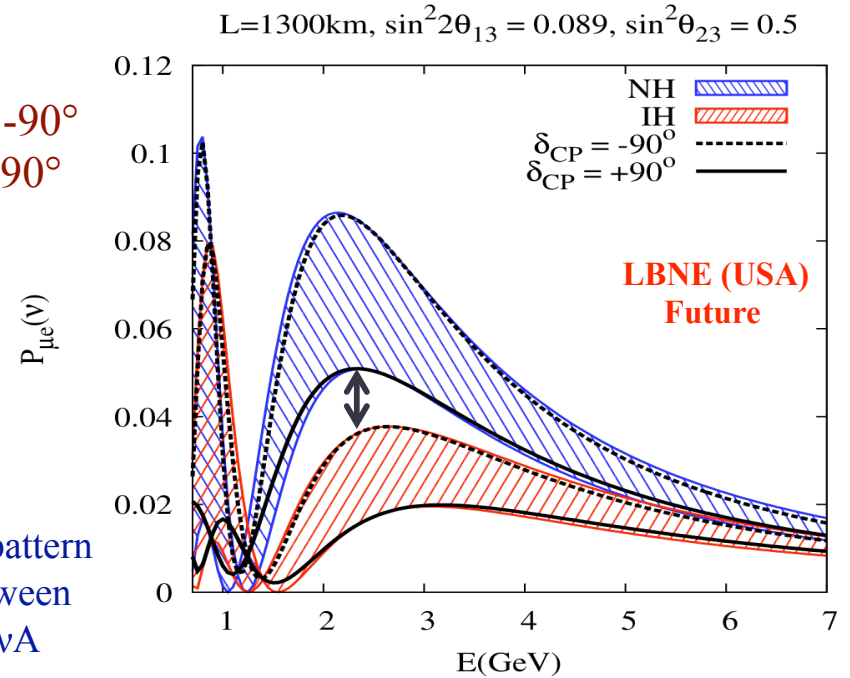

Favorable combinations!  
NH, LHP ( $-180^\circ$  to  $0^\circ$ )  
IH, UHP ( $0^\circ$  to  $180^\circ$ )

Large  $\theta_{13}$  causes large  
Earth matter effects!

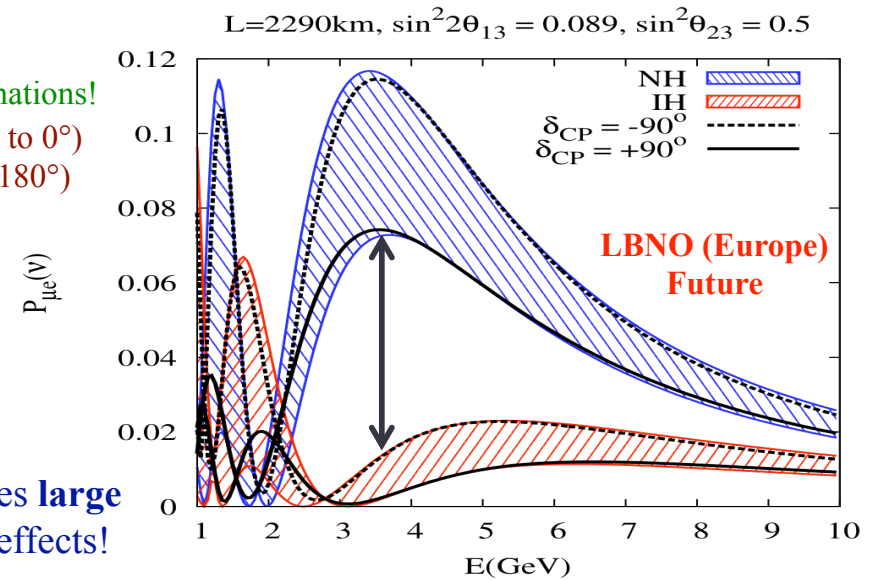

Agarwalla, Prakash, Raut, Sankar, 2012-2013

# Octant – $\delta_{CP}$ degeneracy in $\nu_{\mu} \rightarrow \nu_e$ oscillation channel

L=810km,  $\sin^2 2\theta_{13} = 0.089$ , NH

L=2290km,  $\sin^2 2\theta_{13} = 0.089$ , NH

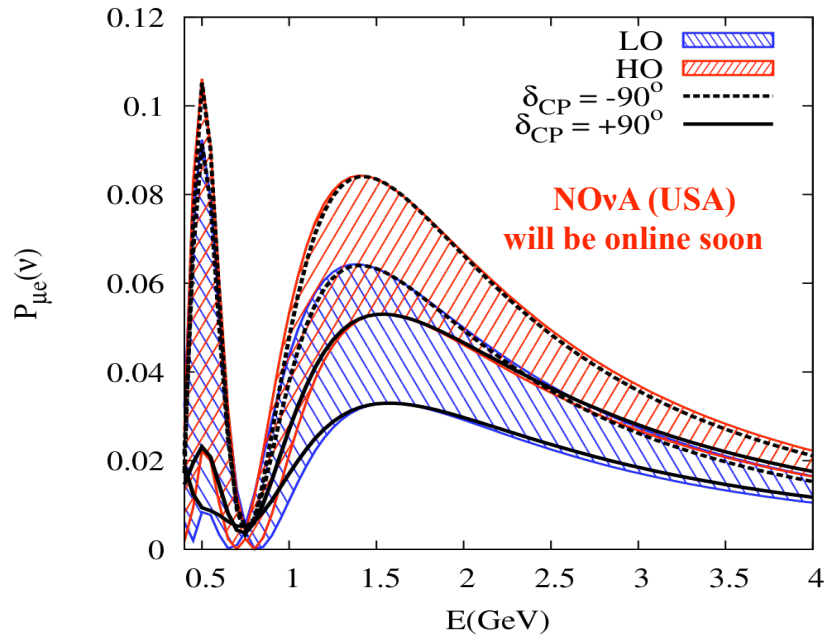

For  $\nu$ :  
 Max: HO,  $-90^\circ$   
 Min: LO,  $90^\circ$

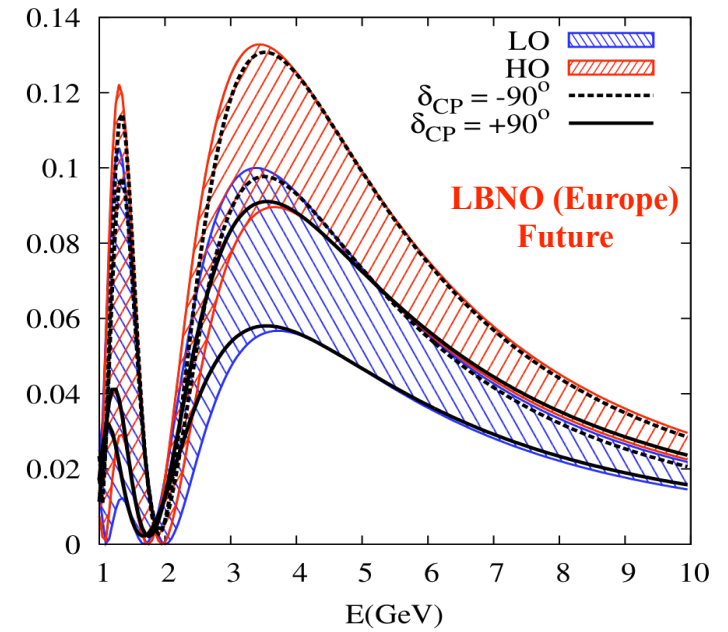

Unfavorable CP values for neutrino are favorable for anti-neutrino and vice-versa!

L=810km,  $\sin^2 2\theta_{13} = 0.089$ , NH

L=2290km,  $\sin^2 2\theta_{13} = 0.089$ , NH

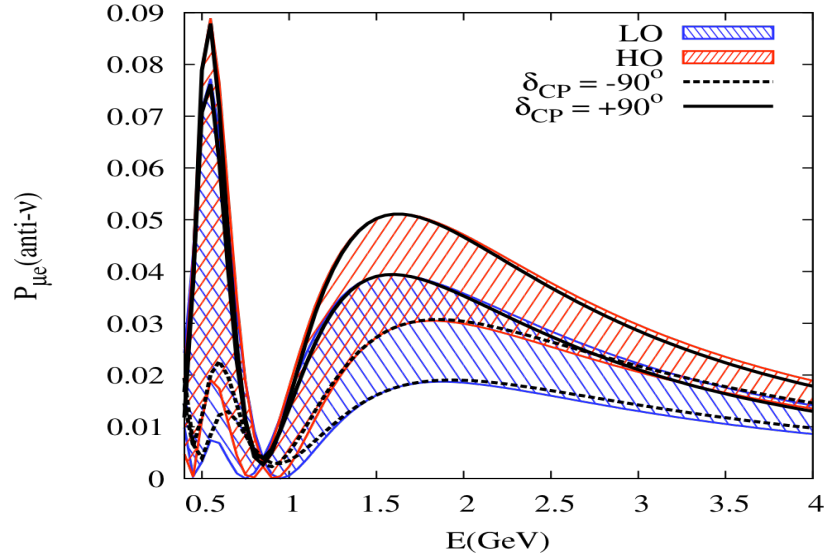

For anti-neutrino:  
 Max: HO,  $90^\circ$   
 Min: LO,  $-90^\circ$

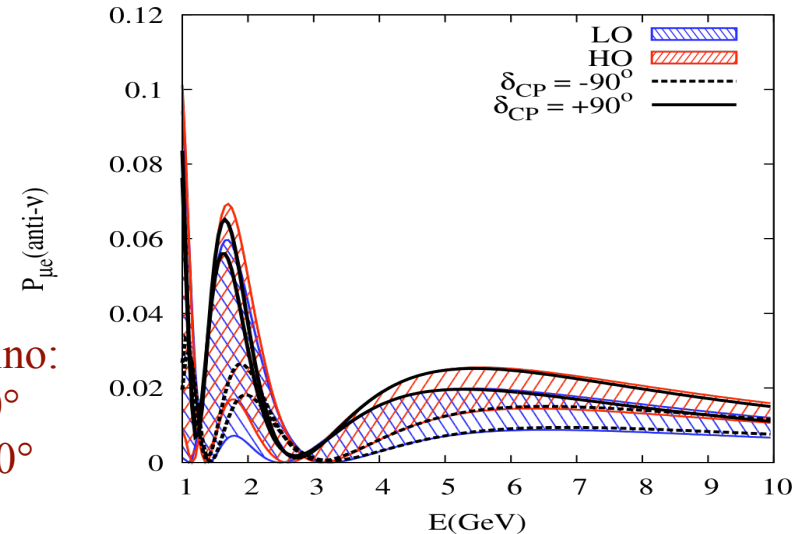

Agarwalla, Prakash, Sankar, 2013

# Bi-Event Plots for T2K and NOvA

T2K[2.5+2.5]

T2K & NOvA: both off-axis experiments

NOvA[3+3]

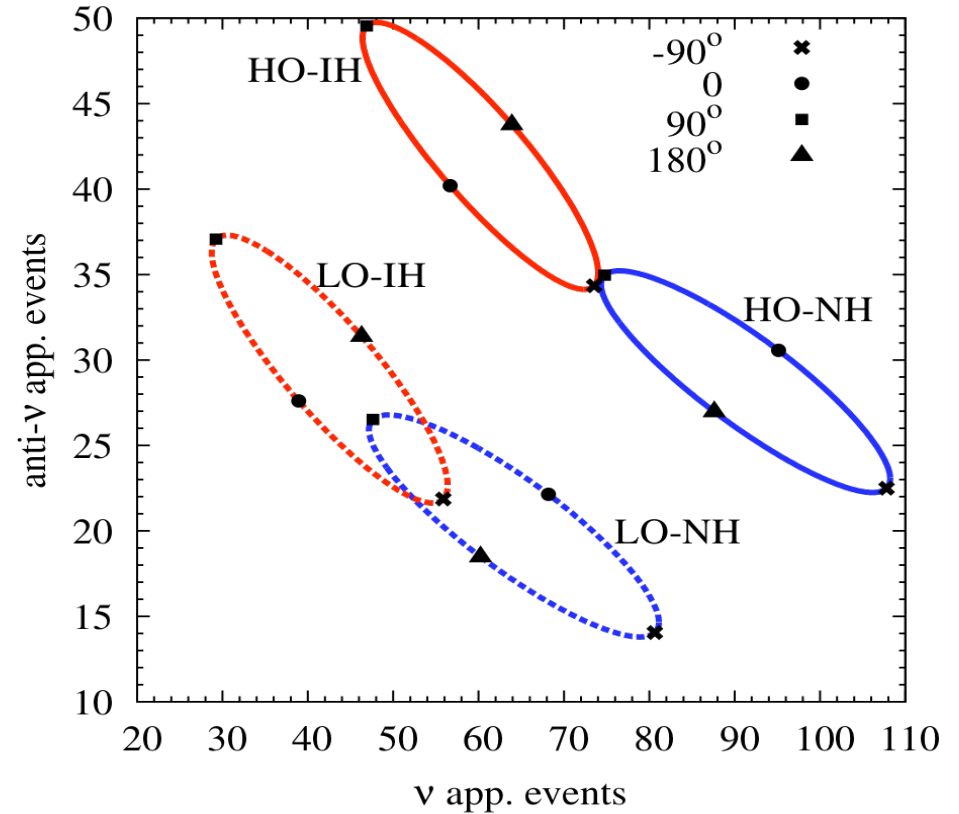
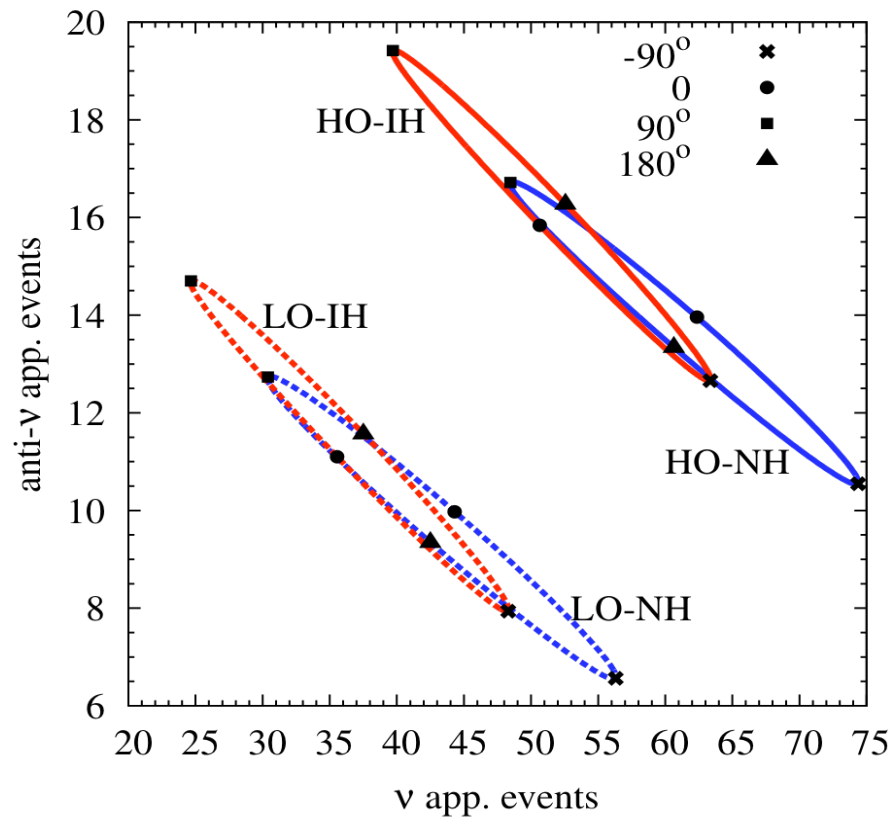

Agarwalla, Prakash, Sankar, arXiv:1301.2574 [hep-ph]

$\nu$  vs. anti- $\nu$  events for various octant-hierarchy combinations, ellipses due to varying  $\delta_{CP}$ !

If  $\delta_{CP} = -90^\circ$  ( $90^\circ$ ), the asymmetry between  $\nu$  and anti- $\nu$  events is largest for NH (IH)

**Hierarchy discovery:** data from two experiments with widely different baselines mandatory!

**Octant discovery:** balanced  $\nu$  & anti- $\nu$  runs needed in each experiment!

# Mass Hierarchy & CP Violation Discovery with T2K and NOvA

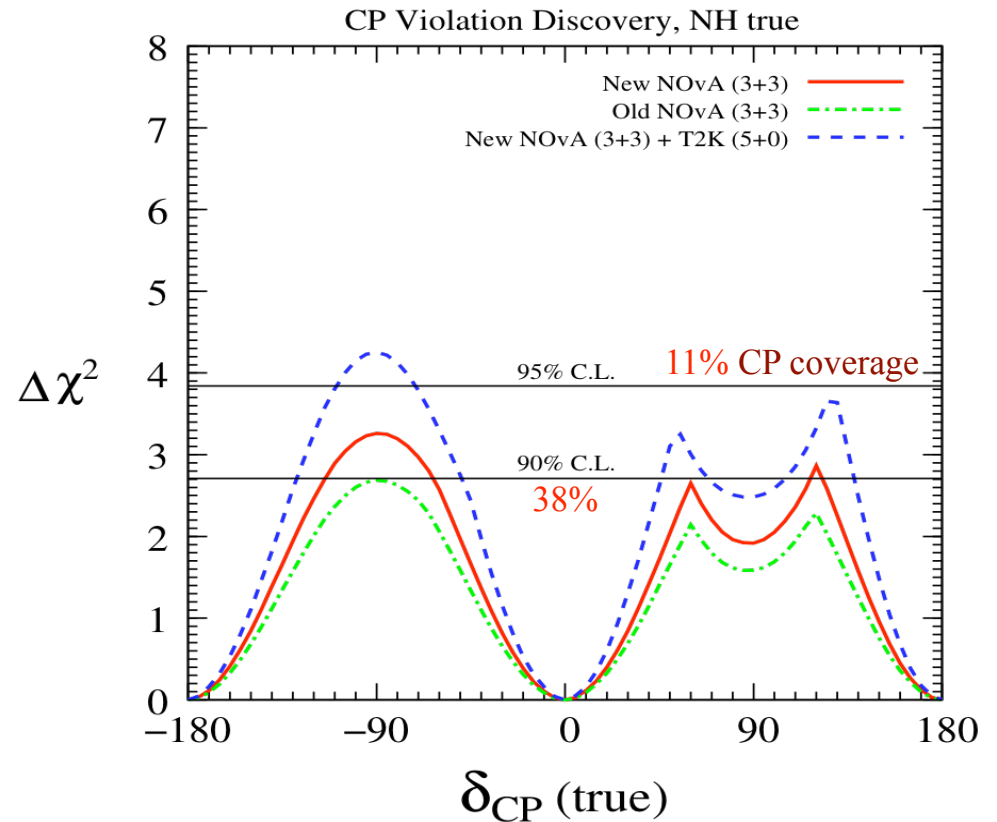
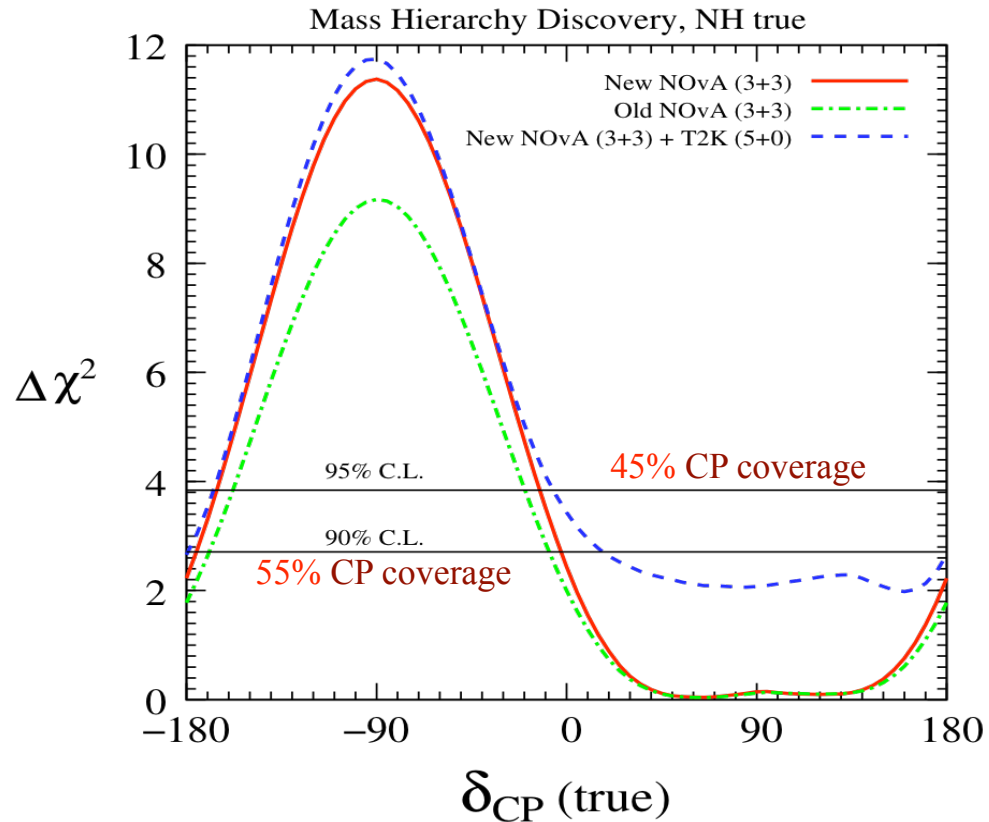

Agarwalla, Prakash, Raut, Sankar, JHEP 1212, 075 (2012)

For large  $\theta_{13}$ , NOvA has reoptimized its event selection criteria. Relaxing the cuts, they now allow more events in both signal and background. Additional NC backgrounds are reconstructed at lower energies and can be managed by a kinematical cut!

**Adding data from T2K and NOvA is useful to kill the intrinsic degeneracies!**

CP asymmetry  $\propto 1/\sin 2\theta_{13}$ , large  $\theta_{13}$  increases statistics but reduces asymmetry, Systematics are important!



# Add a small LArTPC in the NOvA Beam Line

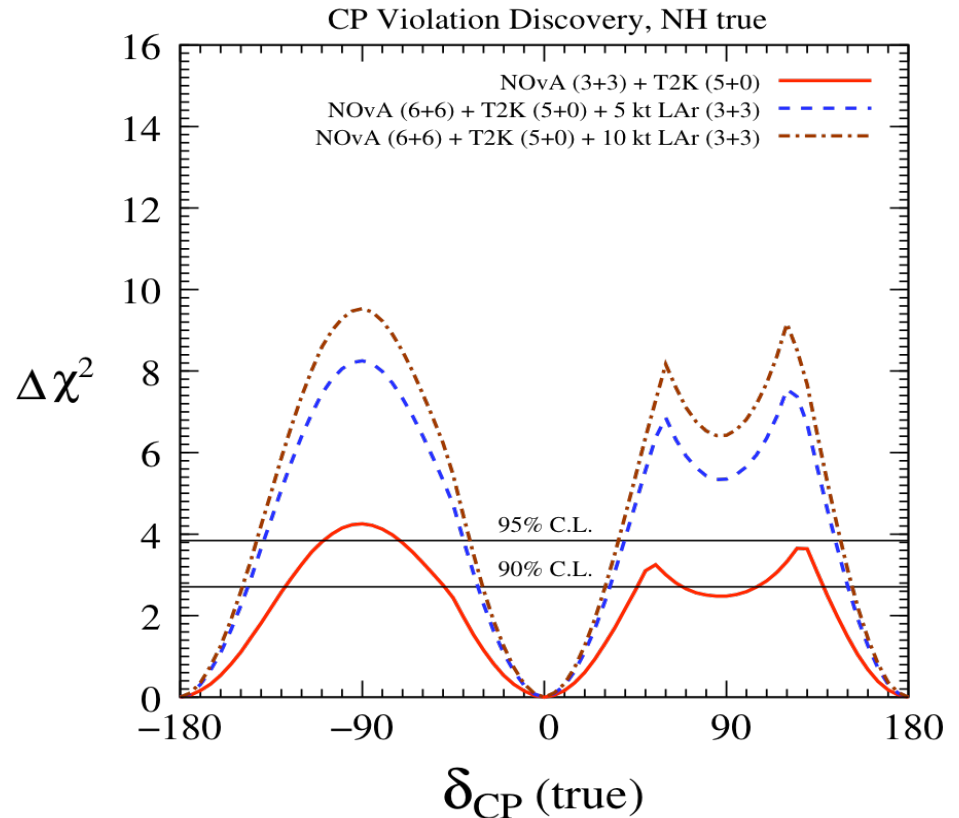
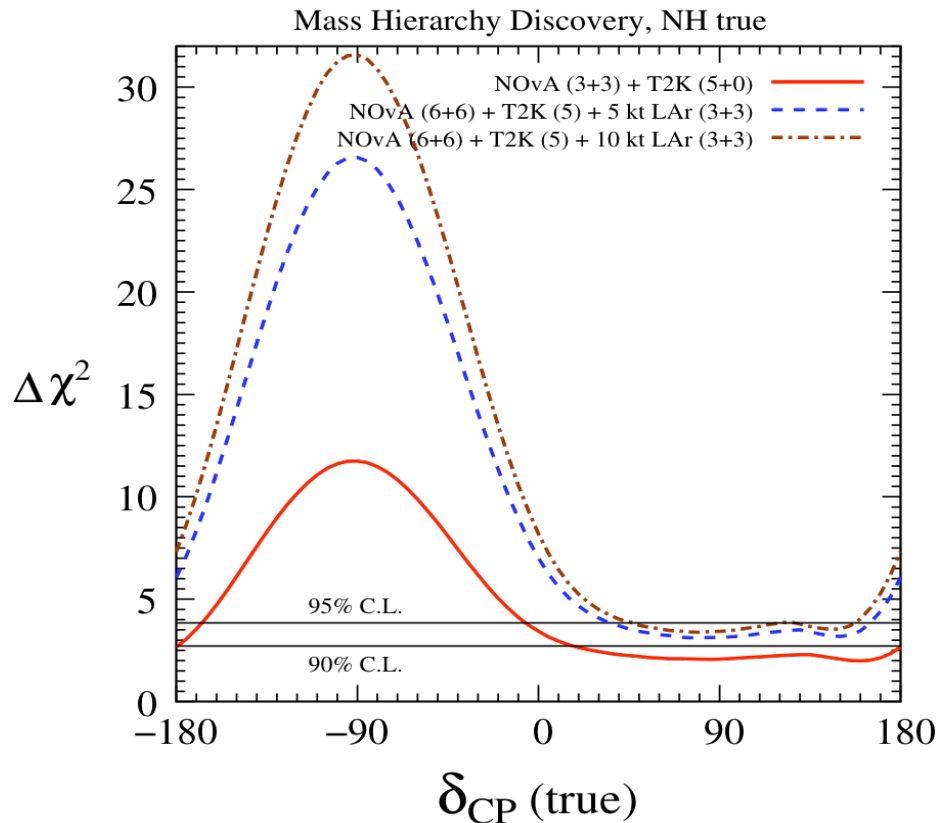

Agarwalla, Prakash, Raut, Sankar, JHEP 1212, 075 (2012)

Add a small LArTPC (5 to 10 kton) in the NOvA Beam Line taking data simultaneously!

**Mass Hierarchy: 100% CP coverage @ 90% C.L. & 64% CP coverage @ 95% C.L. w/ 5 kt LArTPC**

**CP Violation: 64% CP coverage @ 90% C.L. & 56% CP coverage @ 95% C.L. w/ 5 kt LArTPC**

# Resolving Octant of $\theta_{23}$ with T2K and NOvA

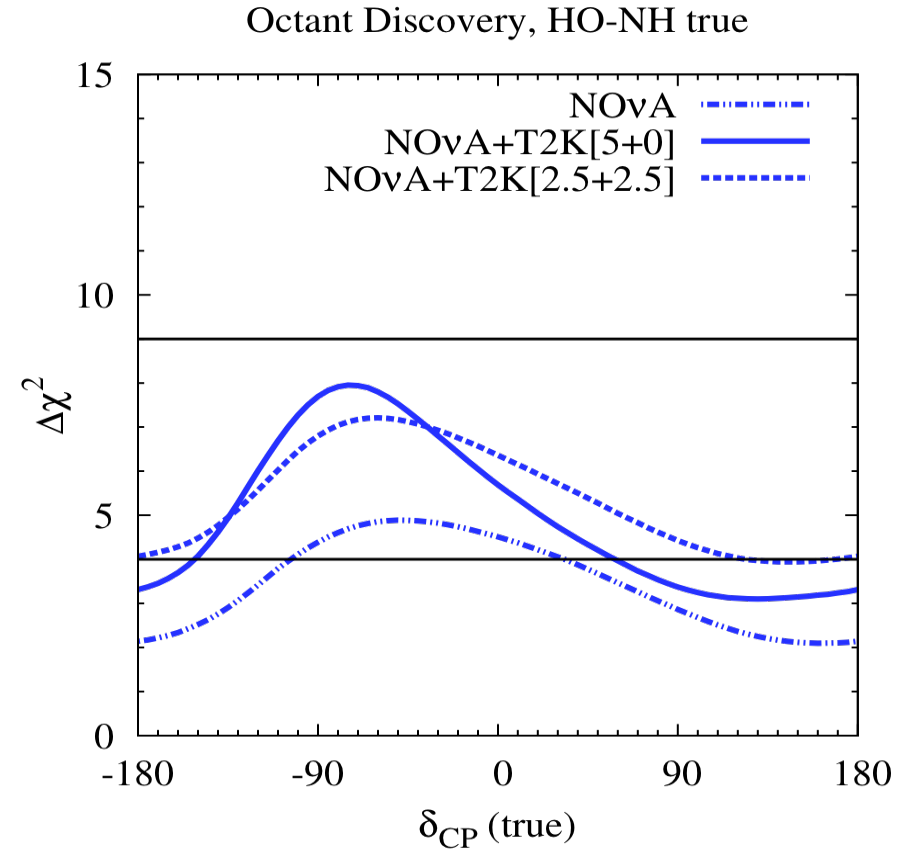
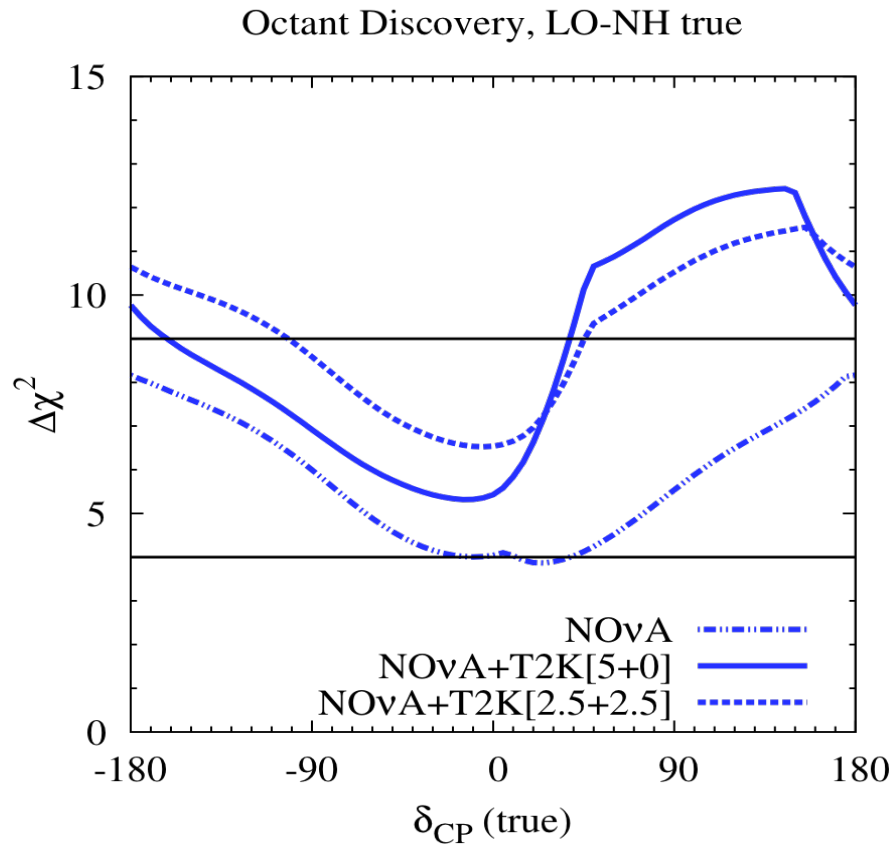

Agarwalla, Prakash, Sankar, arXiv:1301.2574 [hep-ph]

A  $2\sigma$  resolution of the octant, for all combinations of neutrino parameters, becomes possible if we add the balanced neutrino and anti-neutrino runs from T2K (2.5 years  $\nu$  + 2.5 years anti- $\nu$ ) and NOvA (3 years  $\nu$  + 3 years of anti- $\nu$ )

**Important message: T2K must run in anti-neutrino mode in future!**

# Octant discovery in $\theta_{23}$ (true) – $\delta_{CP}$ (true) plane with T2K & NOvA

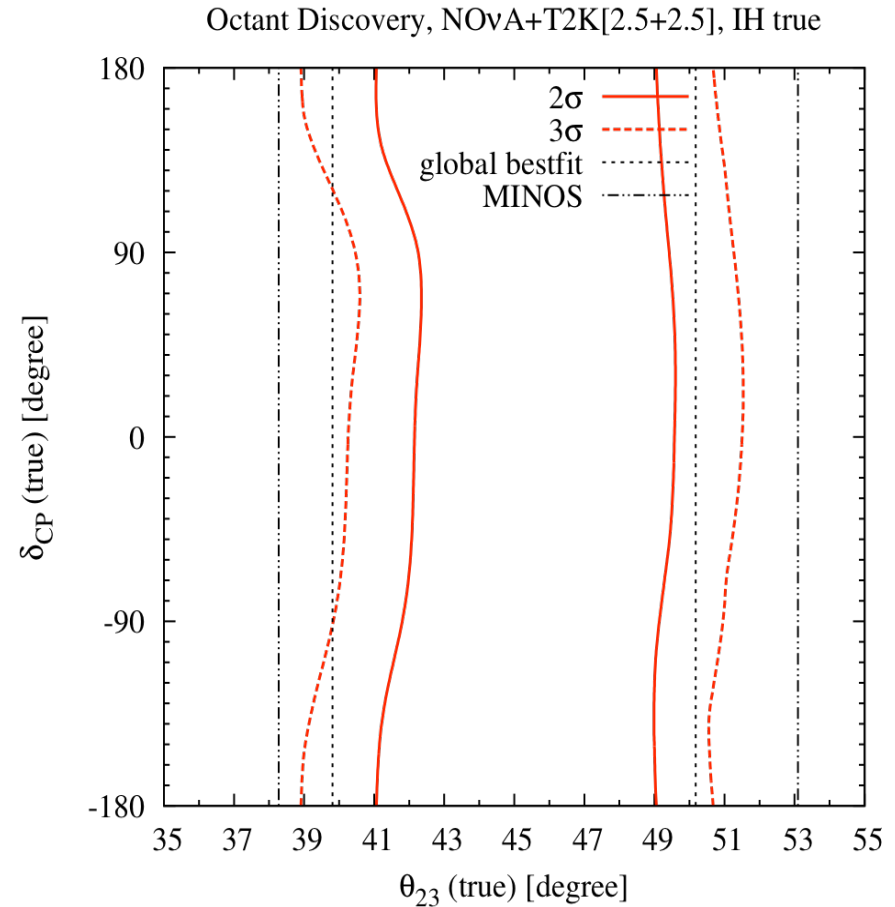
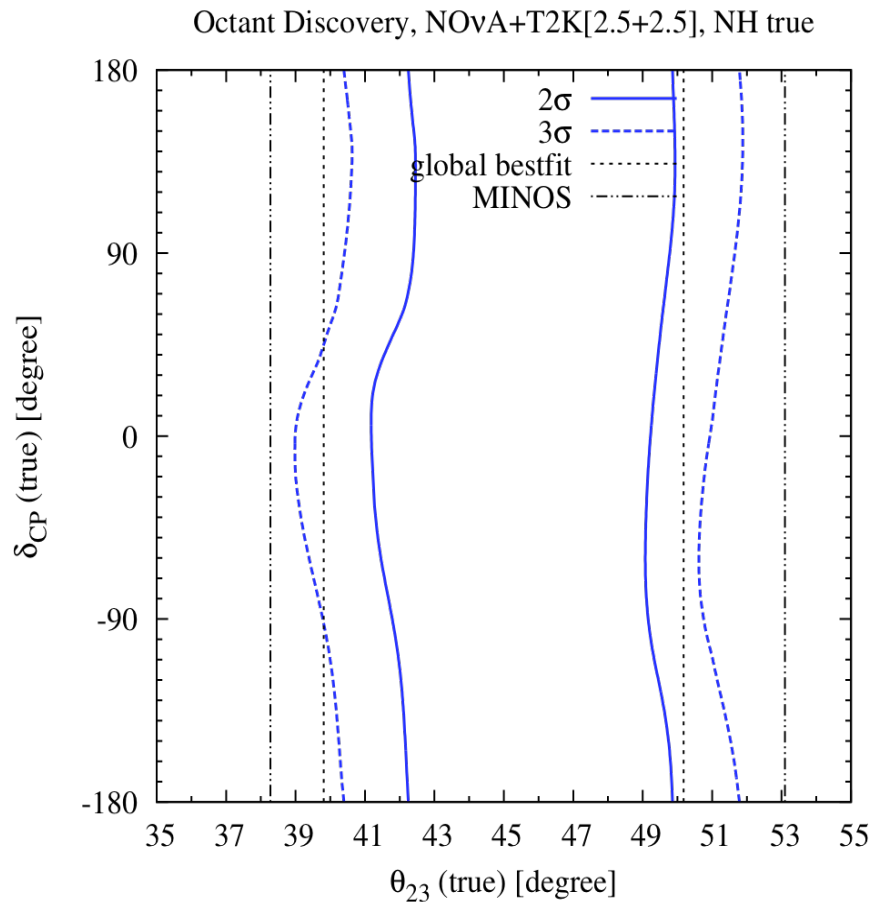

Agarwalla, Prakash, Sankar, arXiv:1301.2574 [hep-ph]

See also, Chatterjee, Ghoshal, Goswami, Raut, arXiv:1302.1370 [hep-ph]

With Normal Hierarchy

If  $\theta_{23} < 41^\circ$  or  $\theta_{23} > 50^\circ$ , we can resolve the octant issue at  $2\sigma$  irrespective  $\delta_{CP}$

If  $\theta_{23} < 39^\circ$  or  $\theta_{23} > 52^\circ$ , we can resolve the octant issue at  $3\sigma$  irrespective  $\delta_{CP}$

# Future Facilities for Long Baseline Neutrino Experiments

## In USA

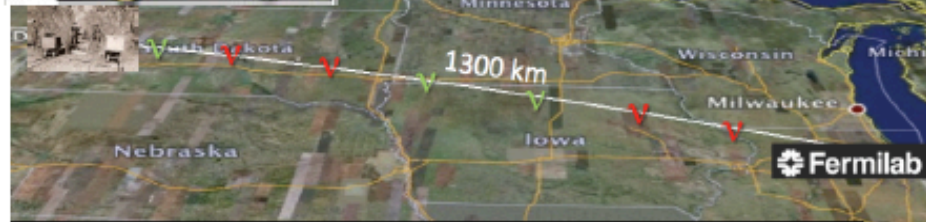
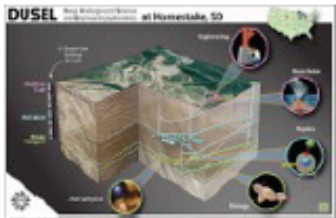

LBNE – a plan to build a new neutrino beam at Fermilab aimed at Homestake, where either a large water Cerenkov detector or a LAr tracking calorimeter would be built

## In Japan

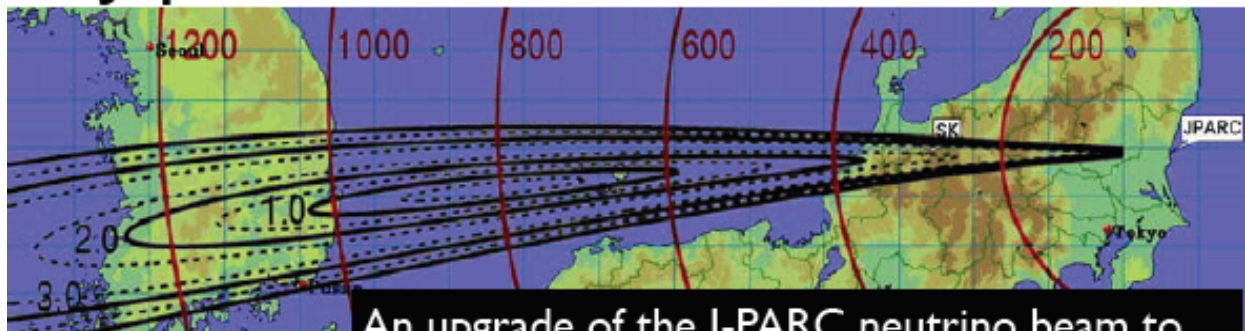

An upgrade of the J-Parc neutrino beam to reach 1.6 MW beam power and new far detector(s) at Kamioka, Okinoshima, or Korea

## In Europe

**LAGUNA**  
European design study for Large Apparatus for Grand Unification and Neutrino Astrophysics

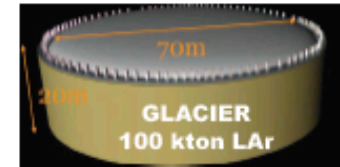

**LAGUNA-LBNO**

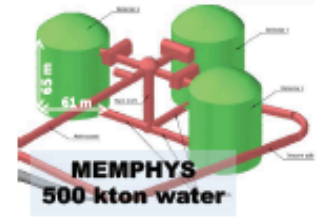

LAGUNA/LAGUNA-LBNO – study considering three detector options for astroparticle physics and new long baseline in Europe

*Each of the three community ≈ same size*

Courtesy to A. Rubbia

# Future Superbeam Expts with LAr Detector: LBNE & LBNO

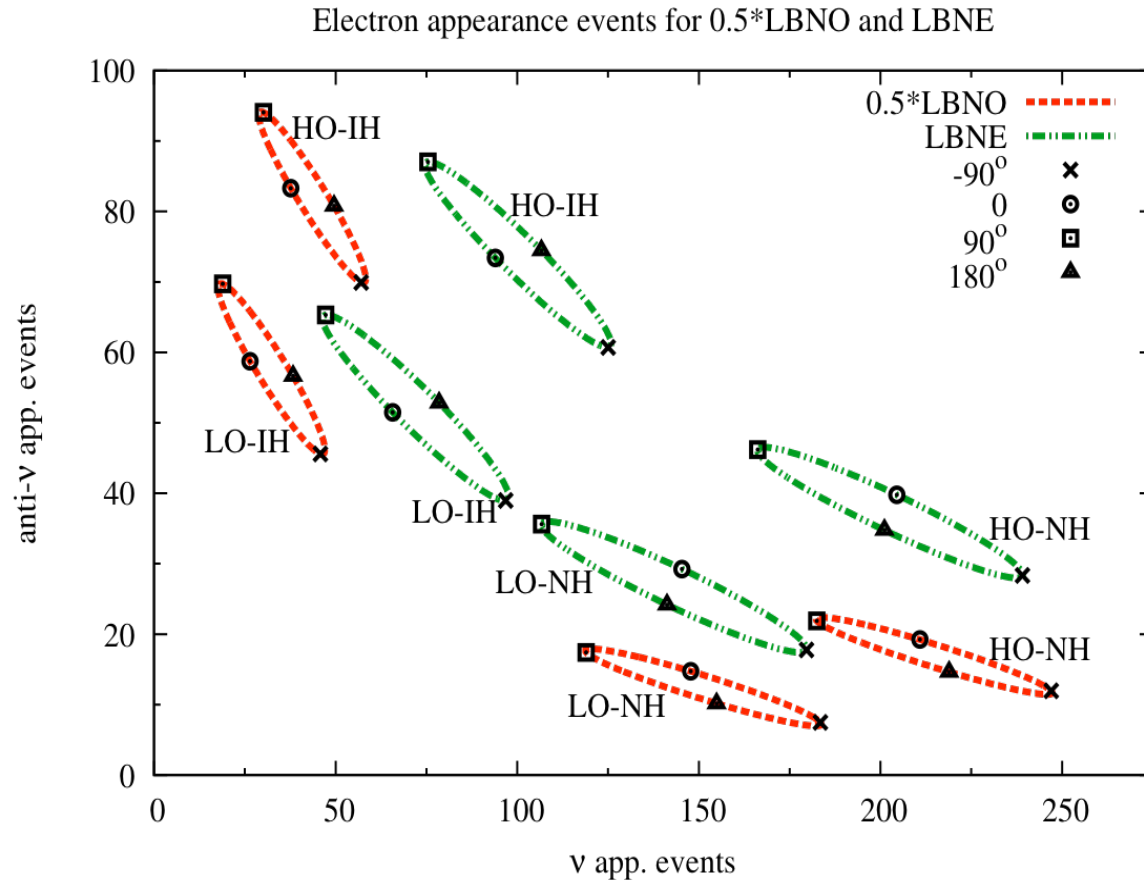

Agarwalla, Prakash, Sankar, arXiv:1304.3251 [hep-ph]

Wide Band Beam → Higher statistics → cover several L/E values → kill clone solutions

LAr Detector → Excellent Detection efficiency at 1<sup>st</sup> & 2<sup>nd</sup> Osc. maxima, good background rejection!

High L → High E → High cross-section → Less uncertainties in cross-section at high E

**LBNO:** CERN-Pyhasalmi (2290 km)  
750 kW beam power, 20 kt LArTPC

**0.5\*LBNO:** 2 (LO/HO)-IH ellipses well separated from 2 (LO/HO)-NH ellipses!  
Excellent hierarchy discrimination capability with just neutrino data!

For octant, balanced  $\nu$  & anti- $\nu$  data must!

**LBNE:** FNAL-Homestake (1300 km)  
708 kW beam power, 10 kt LArTPC

For LBNE, in case of LO, hierarchy discovery is very limited!

Octant determination in LBNE is similar to 0.5\*LBNO!

# Hierarchy Discovery with LBNE and LBNO

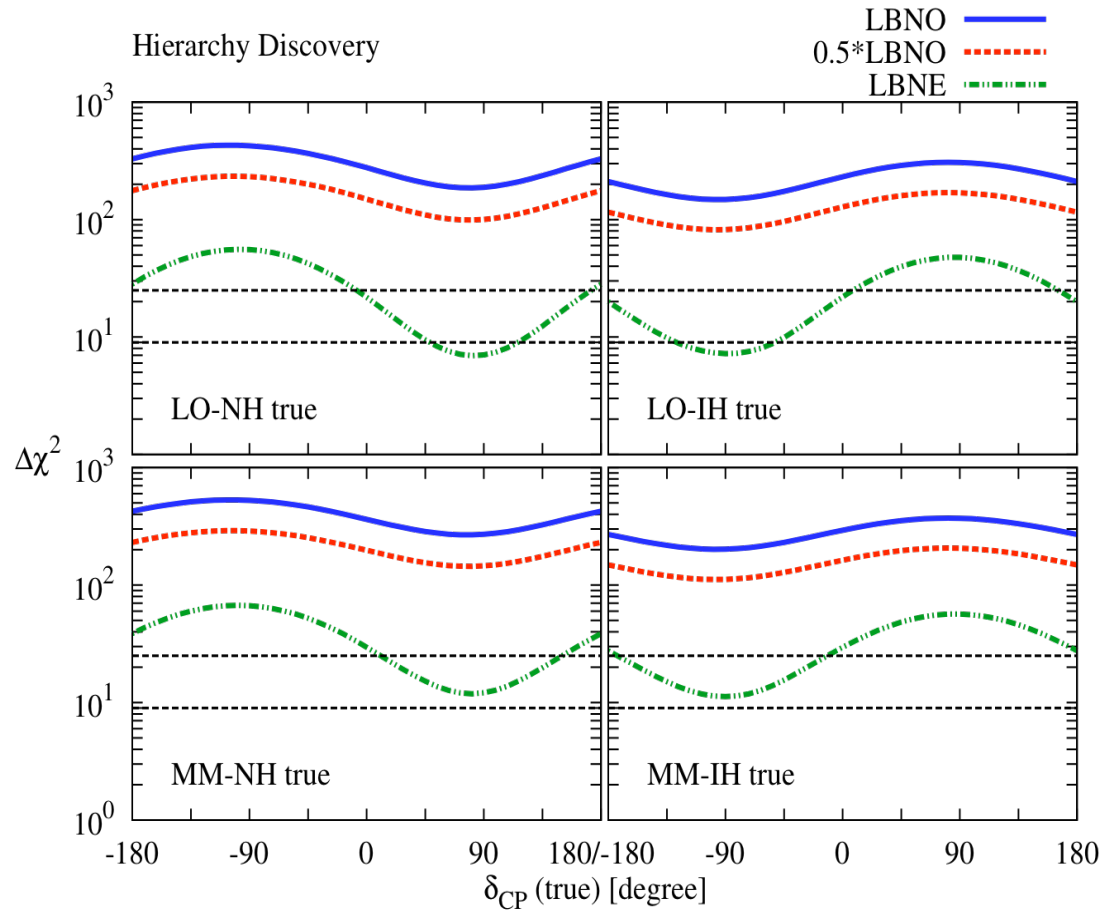

Mass hierarchy issue need to be resolved at high C.L. before we look for CPV discovery!

First phases of LBNE & LBNO: limited reach for CPV, only for 10-20% of the entire range, at  $3\sigma$  C.L.!

Agarwalla, Prakash, Sankar, arXiv:1304.3251 [hep-ph]

Even a 50% scaled down version of LBNO has a  $\sim 10\sigma$  hierarchy discovery potential for all octant-hierarchy combinations and for any  $\delta_{CP}$ !

LBNE in its first phase will not provide a  $5\sigma$  hierarchy discovery for about 50% of the  $\delta_{CP}$  range!

If NOvA indicates unfavorable hierarchy- $\delta_{CP}$  choice, LBNE must increase their exposure in first phase!

# Octant Discovery with LBNE and LBNO

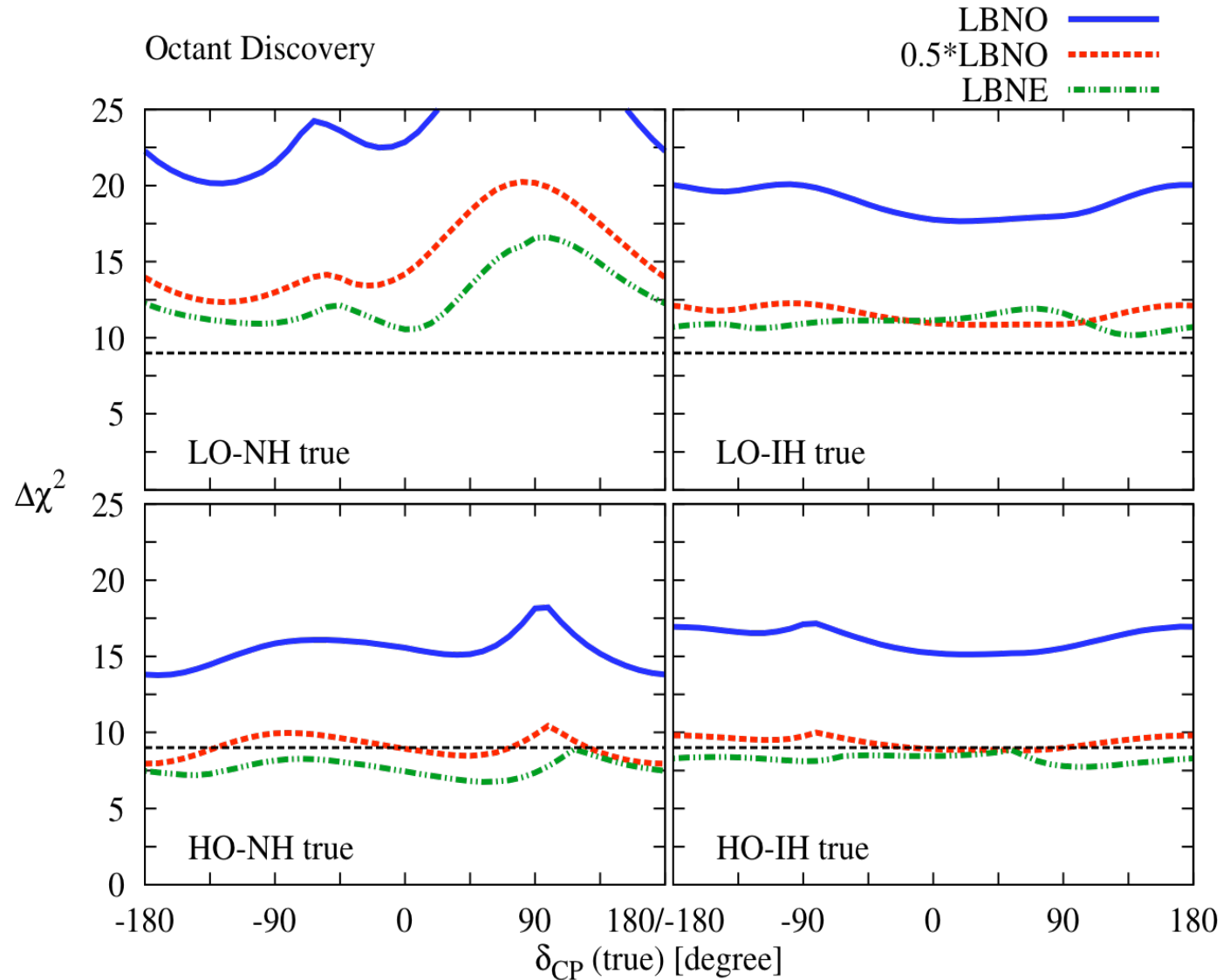

Agarwalla, Prakash, Sankar, arXiv:1304.3251 [hep-ph]

**For octant:  $4\sigma$  discovery for LBNO and  $3\sigma$  for LBNE!**

# *CP violation Discovery with LBNE and LBNO*

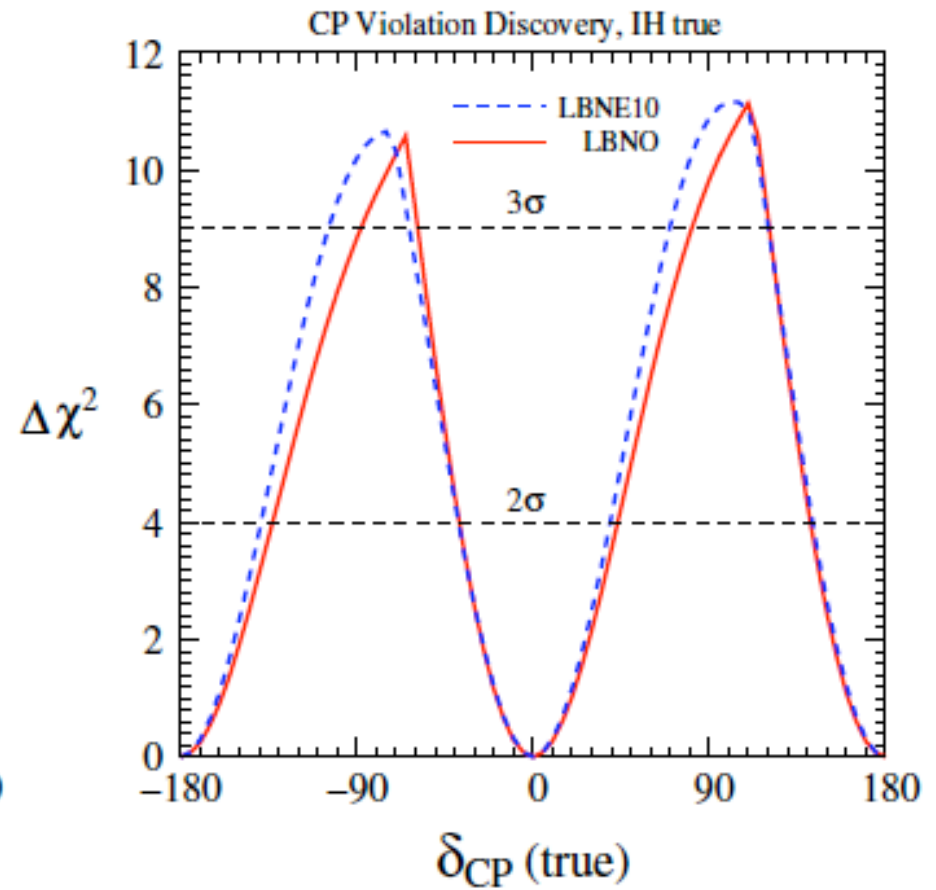
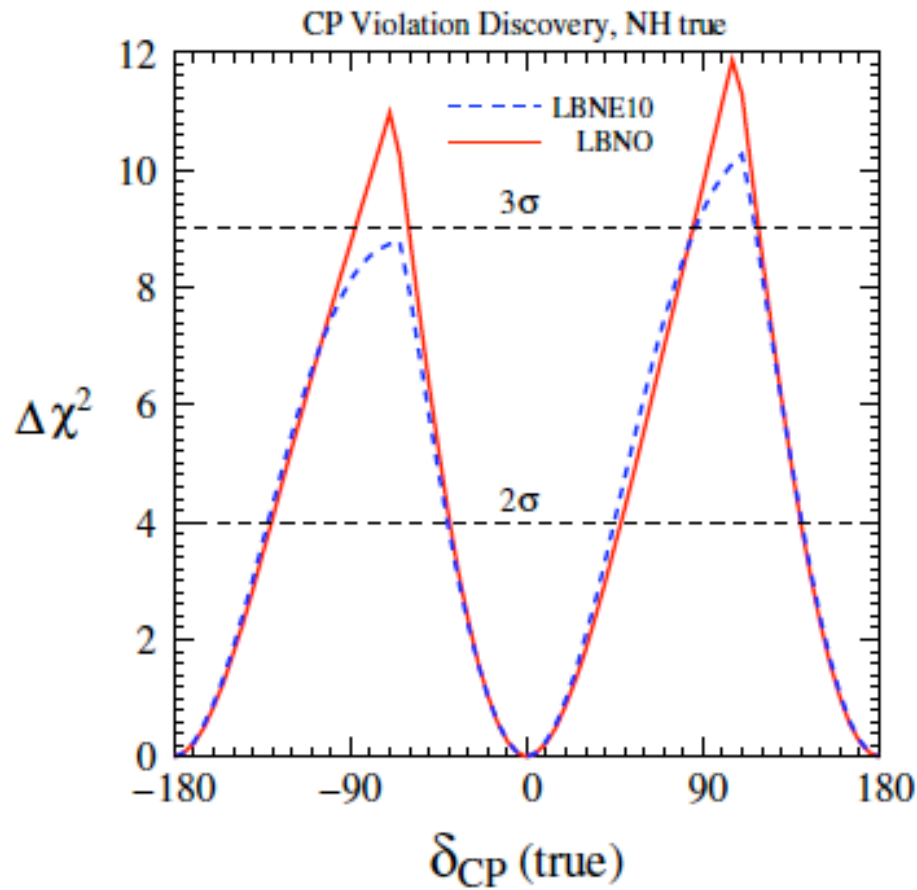

Setups	Fraction of $\delta_{CP}(\text{true})$	
	$2\sigma$	$3\sigma$
LBNE10 (5 years $\nu$ + 5 years $\bar{\nu}$ )	0.52 (0.56)	0.09 (0.26)
LBNO (5 years $\nu$ + 5 years $\bar{\nu}$ )	0.51 (0.54)	0.17 (0.19)



## *India-based Neutrino Observatory*

*India-based Neutrino Observatory collaboration is going to build a massive 50 kilotons magnetized Iron Calorimeter (ICAL) detector to study properties of neutrino at Bodi West Hills, Pottipuram, Theni district, Tamil Nadu*

- *The main goal of this detector to study atmospheric neutrinos with a wide range of baselines and neutrino energies*
- *Complementary to ongoing efforts worldwide to explore neutrino properties*
- *Reconfirm neutrino oscillations using neutrinos and anti-neutrinos separately*
- *It has the capability to discover the neutrino mass hierarchy using large Earth's matter effects via charge discrimination*
- *ICAL@INO can improve the precision on atmospheric oscillation parameters*
- *It can measure the deviation of 2-3 mixing angle from its maximal value and can probe its octant*

See the talk by Yogendra Vijoyi

# Muon Efficiencies and Resolutions of ICAL@INO

Reconstruction Efficiency

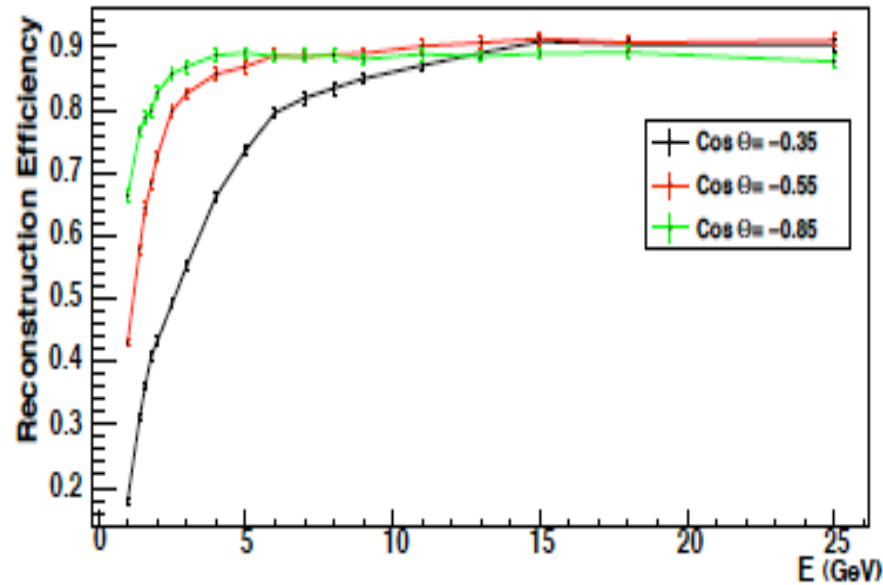

CID Efficiency

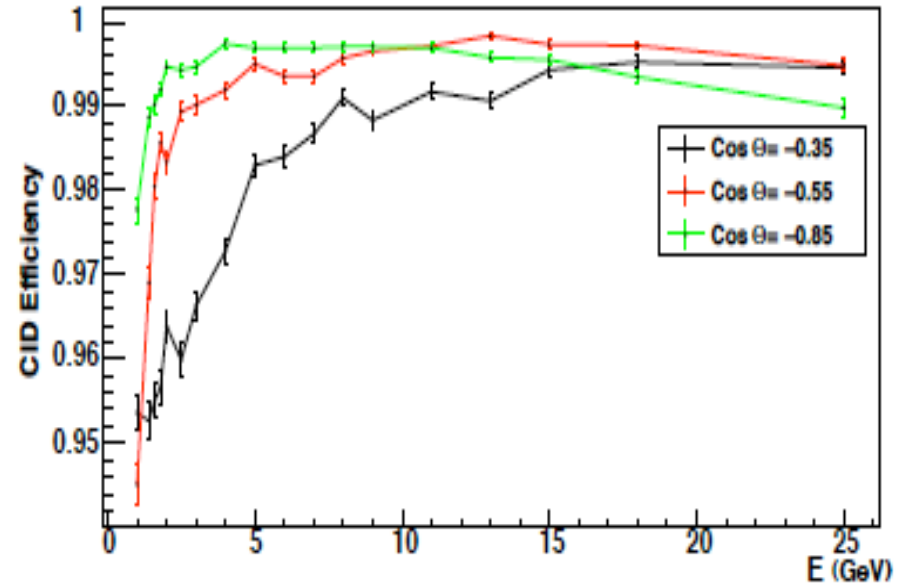

$\cos \theta$  Resolution

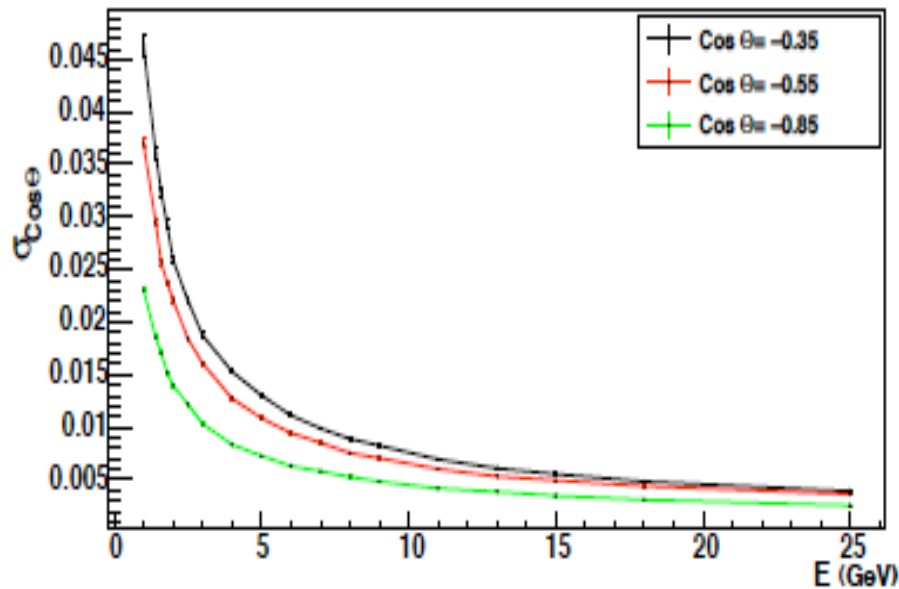

Energy Resolution

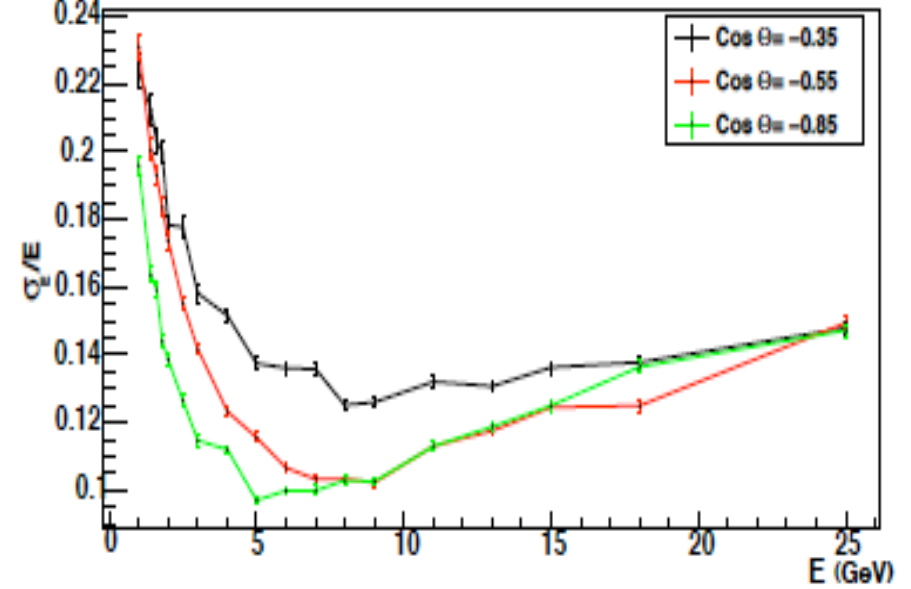

# Precision of Atmospheric Oscillation Parameters

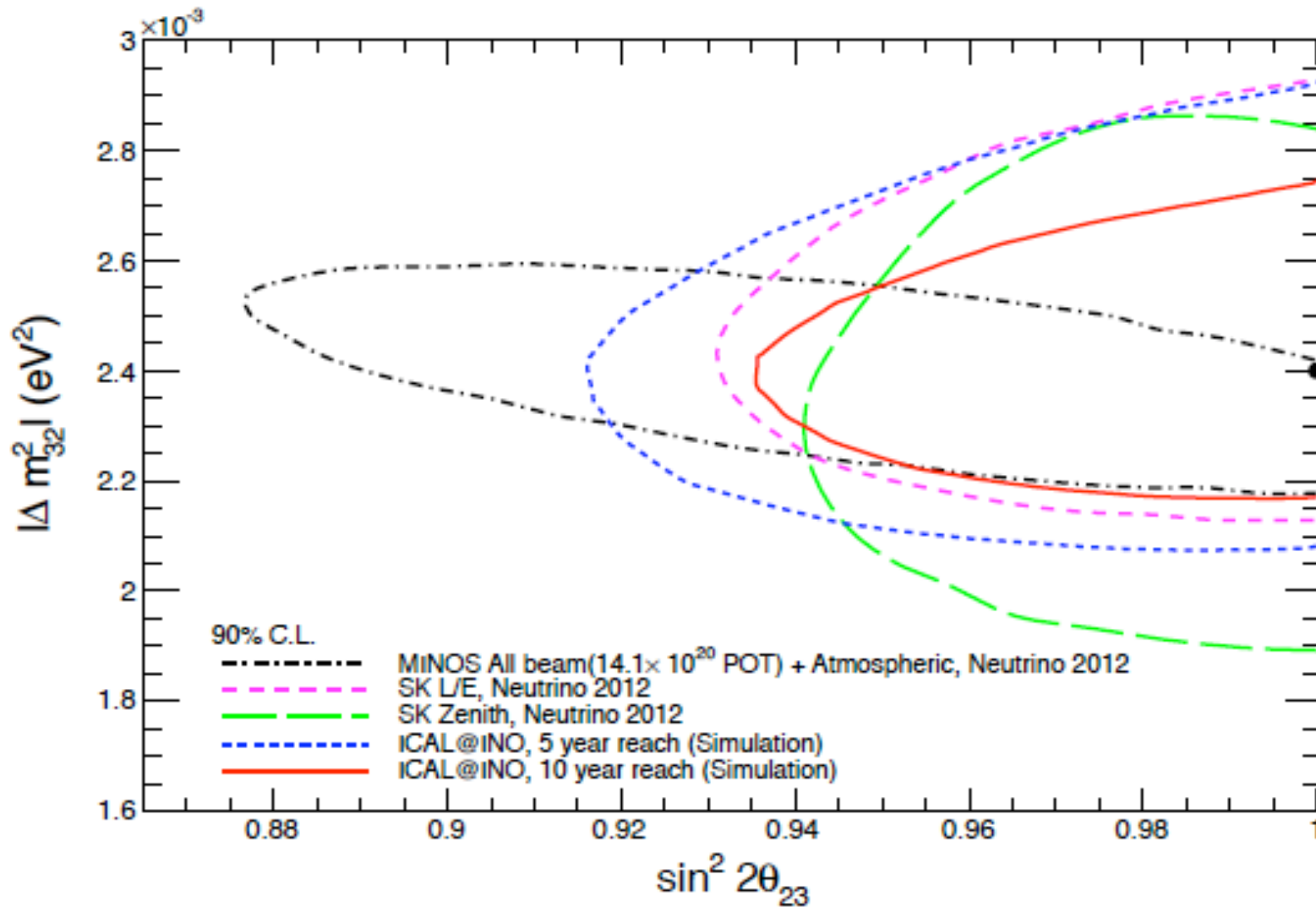

Thakore, Ghosh, Choubey, Dighe, arXiv:1303.2534 [hep-ph] (INO Collaboration)

*Precision complementary to Long-baseline experiments*

# Event Spectrum at ICAL@INO

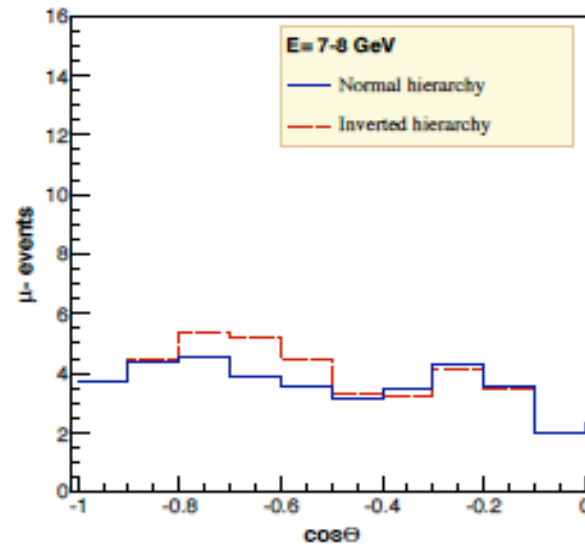
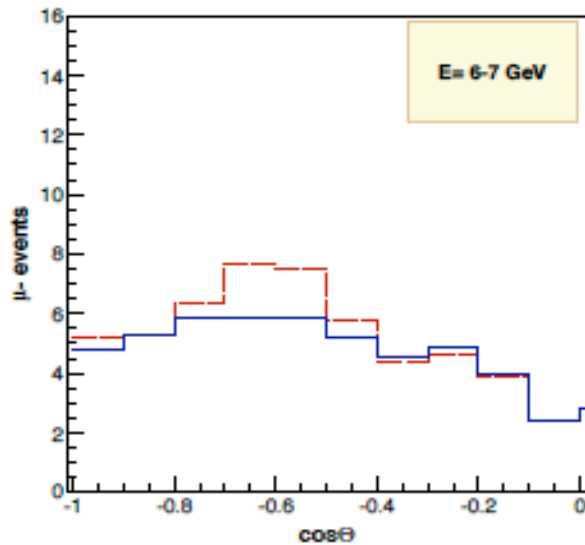
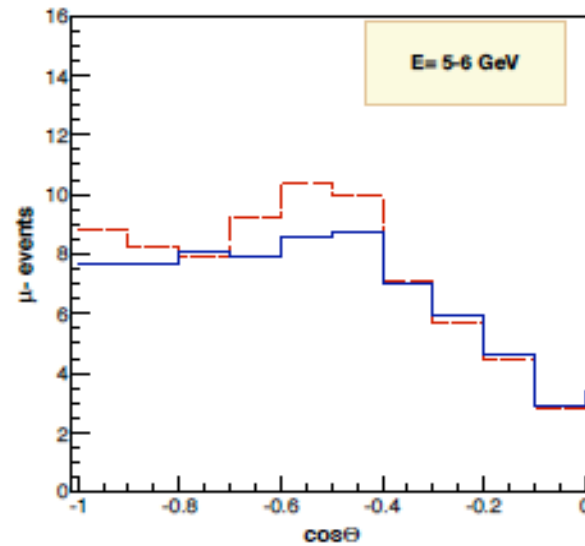
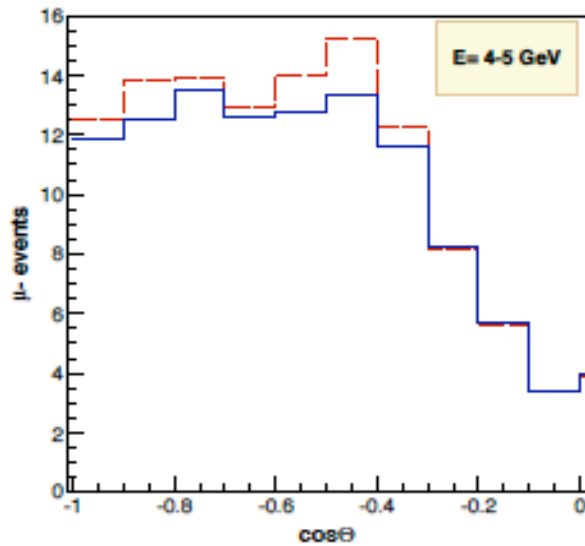

$\mu^-$  event spectrum for 10 years exposure

Comparison between Normal and Inverted Hierarchy!

Thakore, Ghosh, Choubey, arXiv:1212.1305 [hep-ph] (INO Collaboration)

# Mass Hierarchy with ICAL@INO

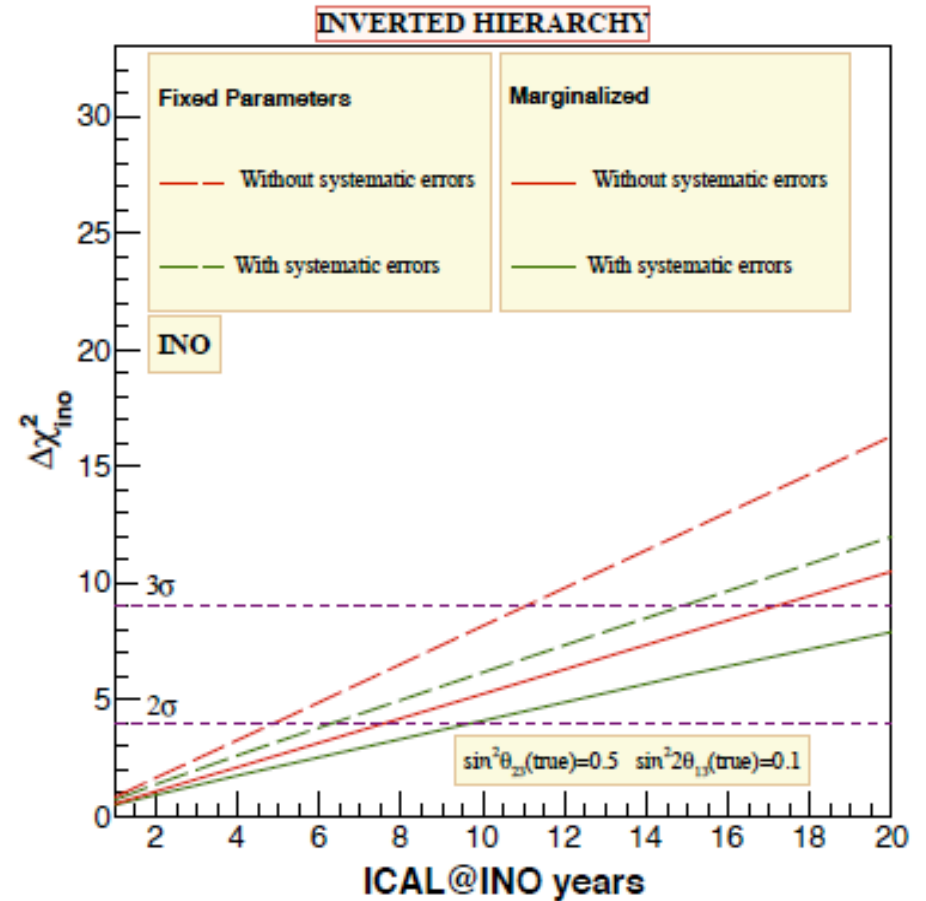
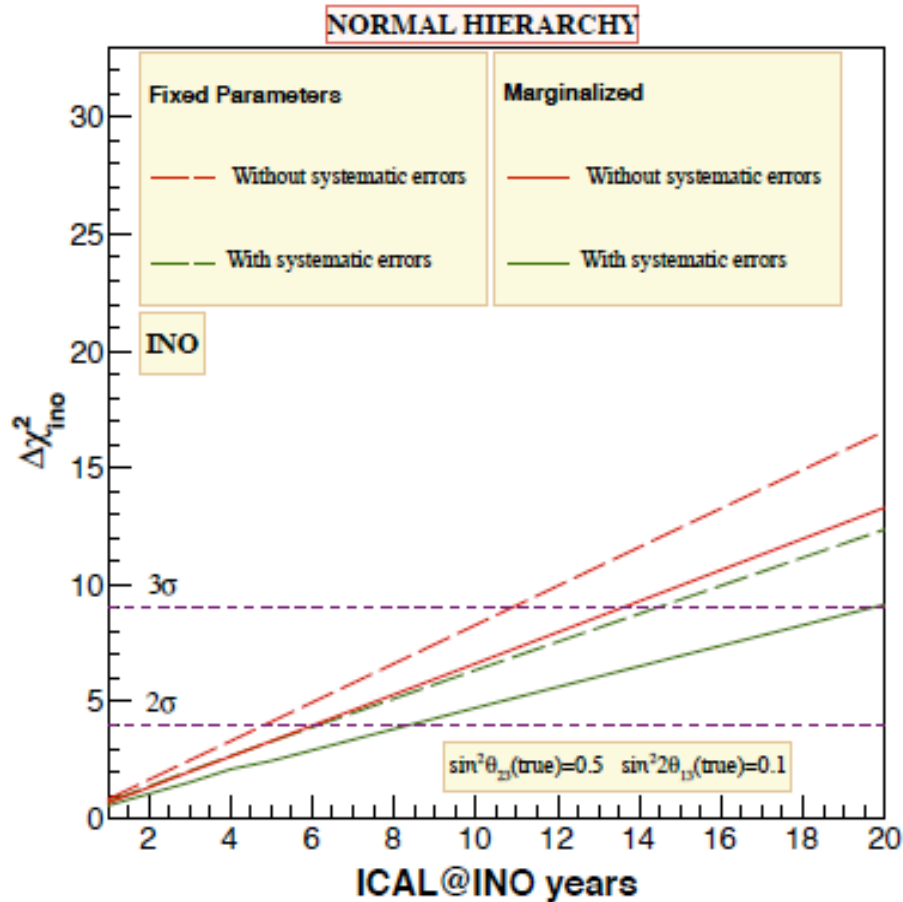

Thakore, Ghosh, Choubey, arXiv:1212.1305 [hep-ph] (INO Collaboration)

*Adding information from Hadrons will enhance the Mass Hierarchy sensitivity*

*Adding data from Reactors, T2K and NOvA will be very crucial!*

## Concluding Remarks

*Recent measurement of a moderately large value of  $\theta_{13}$  signifies an important breakthrough in establishing the standard three flavor oscillation picture of neutrinos!*

*It has opened up exciting possibilities for current & future oscillation experiments!*

*Now we are in the **Diamond Era** of Neutrinos:  
very **challenging** but more **exciting** than before!*

*$\nu$  masses are evidence for BSM physics! We need to put together all other New Physics effects with this like: charged LFV, Collider signals, Cosmo-astroparticle...to establish the New Standard Model!*

## *Concluding Remarks (continued)*

*Neutrinos are key to many unsolved issues at the high energy frontier and a crucial low energy probe of Nature's building blocks*

*No doubt ! Neutrinos will continue to surprise us....*

*!! Stay tuned and let us try to find these surprises !!*

**Thank you for your attention!**

## The New Minimal Standard Model

- Minimal Extensions to give Mass to the Neutrino:

- \* Introduce  $\nu_R$  AND impose  $L$  conservation  $\Rightarrow$  Dirac  $\nu \neq \nu^c$ :

$$\mathcal{L} = \mathcal{L}_{SM} - M_\nu \bar{\nu}_L \nu_R + h.c.$$

- \* NOT impose  $L$  conservation  $\Rightarrow$  Majorana  $\nu = \nu^c$

$$\mathcal{L} = \mathcal{L}_{SM} - \frac{1}{2} M_\nu \bar{\nu}_L \nu_L^C + h.c.$$

- The charged current interactions of leptons are not diagonal (same as quarks)

$$\frac{g}{\sqrt{2}} W_\mu^+ \sum_{ij} (U_{\text{LEP}}^{ij} \bar{\ell}^i \gamma^\mu L \nu^j + U_{\text{CKM}}^{ij} \bar{U}^i \gamma^\mu L D^j) + h.c.$$

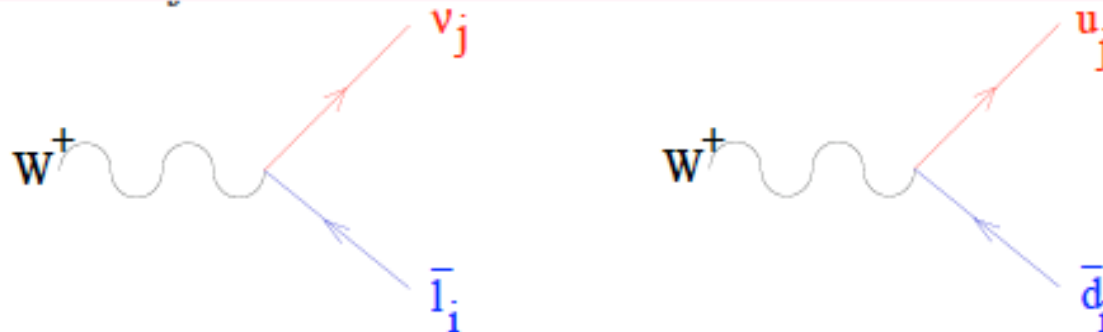

Courtesy to Concha Gonzalez-Garcia



## Neutrino Mass Scale

Single  $\beta$  decay : Dirac or Majorana  $\nu$  mass modify spectrum endpoint

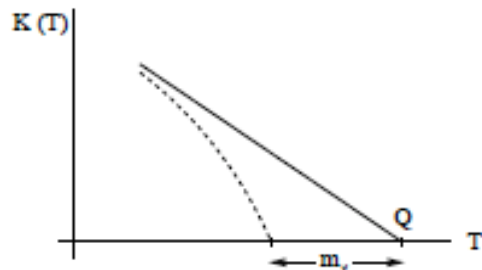

$$m_{\nu_e}^2 = \sum m_j^2 |U_{ej}|^2 = c_{13}^2 c_{12}^2 m_1^2 + c_{13}^2 s_{12}^2 m_2^2 + s_{13}^2 m_3^2$$

$\nu$ -less Double- $\beta$  decay:  $\Leftrightarrow$  Majorana  $\nu$ 's sensitive to Majorana phases

If  $m_\nu$  only source of  $\Delta L$   $(T_{1/2}^{0\nu})^{-1} \propto (m_{ee})^2$

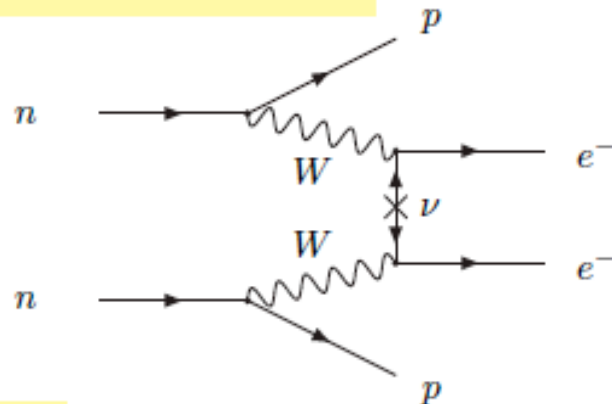

$$m_{ee} = \left| \sum U_{ej}^2 m_j \right|$$

$$= \left| c_{13}^2 c_{12}^2 m_1 e^{i\eta_1} + c_{13}^2 s_{12}^2 m_2 e^{i\eta_2} + s_{13}^2 m_3 e^{-i\delta_{CP}} \right|$$

COSMO Neutrino mass (Dirac or Majorana) modify the growth of structures

$$\sum m_i$$

# Backup Slides (Neutrinoless double beta decay)

## Experimental Limits

Isotope	$0\nu\beta\beta$ half life	Experiment	$\langle m \rangle$ eV
$^{48}\text{Ca}$	$> 1.4 \cdot 10^{22}$ (90%CL)	ELEGANT-VI	$< 7 - 44$
$^{76}\text{Ge}$	$> 1.9 \cdot 10^{25}$ (90%CL)	Heidelberg-Moscow	$< 0.35$
$^{76}\text{Ge}$	$2230^{+440}_{-310}$ (90%CL)	Subset of HM coll.	$0.32 \pm 0.03$
$^{76}\text{Ge}$	$> 2.1 \cdot 10^{25}$ (90%CL)	GERDA†	$< 0.2 - 0.4$
$^{82}\text{Se}$	$> 2.1 \cdot 10^{23}$ (90%CL)	NEMO-3	$< 1.2 - 3.2$
$^{100}\text{Mo}$	$> 5.8 \cdot 10^{23}$ (90%CL)	NEMO-3	$< 0.6 - 2.7$
$^{116}\text{Cd}$	$> 1.7 \cdot 10^{23}$ (90%CL)	Solotvino	$< 1.7$
$^{130}\text{Te}$	$> 2.8 \cdot 10^{24}$ (90%CL)	Cuoricino	$< 0.41 - 0.98$
$^{136}\text{Xe}$	$> 1.9 \cdot 10^{25}$ (90%CL)	KamLAND-Zen††	$< 0.12 - 0.25$
$^{136}\text{Xe}$	$> 1.6 \cdot 10^{25}$ (90%CL)	EXO-200†††	$< 0.14 - 0.38$
$^{150}\text{Nd}$	$> 1.8 \cdot 10^{22}$ (90%CL)	NEMO-3	

Courtesy to Liang Yang

[F. Avignone, S. Elliot, J. Engel, arXiv:0708: 1033v2 (2007)]

† [GERDA Collaboration, arXiv:1307.4720 (2013)]

†† [KamLAND-Zen Collaboration, Phys. Rev. Lett. 110, 062502(2013)]

††† [EXO Collaboration, Phys. Rev. Lett.109, 0322505 (2012)]

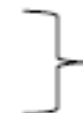

New results within  
the last year!

# Experimental Sensitivity to Neutrino Mass

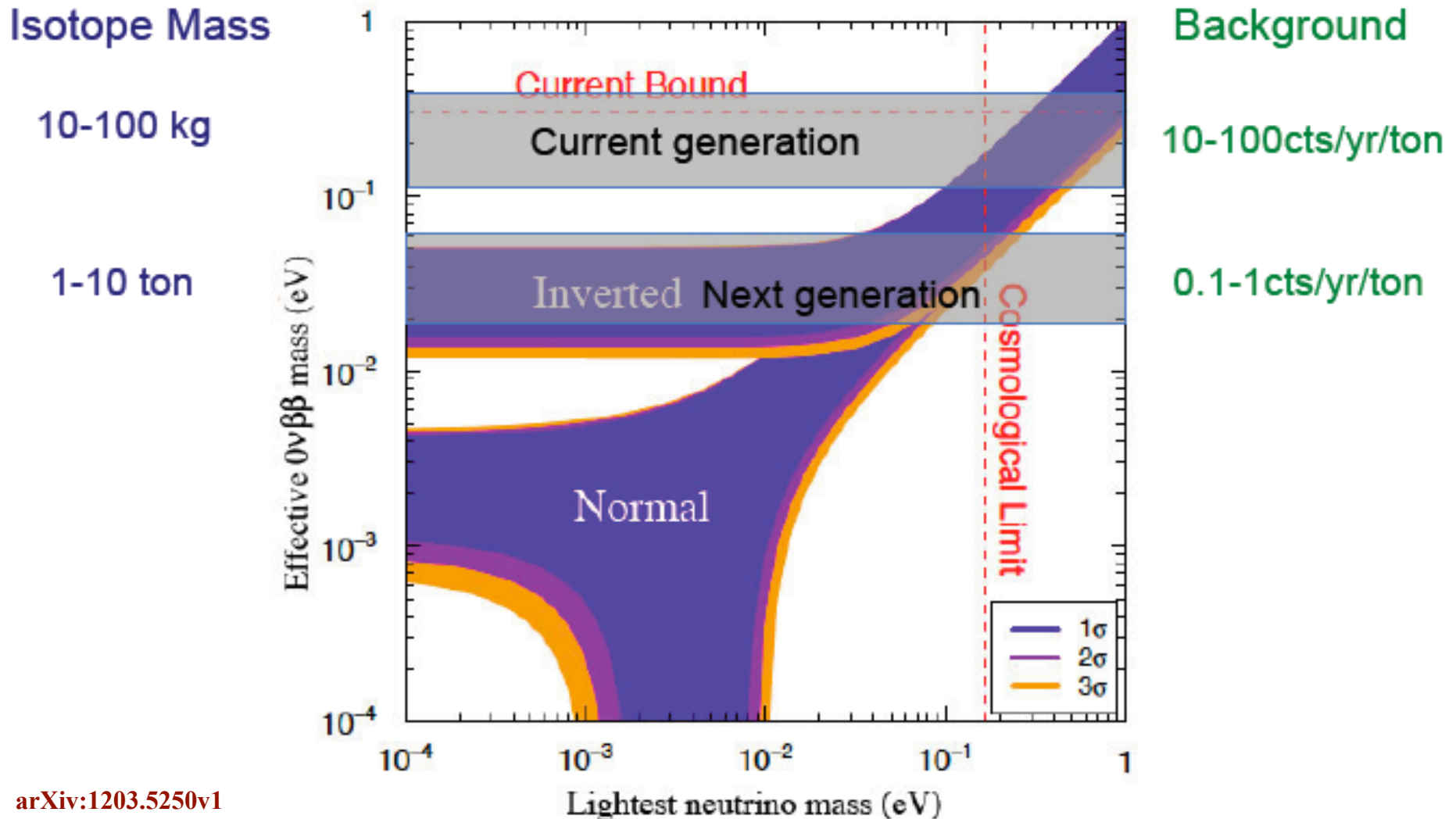

arXiv:1203.5250v1

Courtesy to Liang Yang

# Backup Slides (See-Saw & Neutrino Mass)

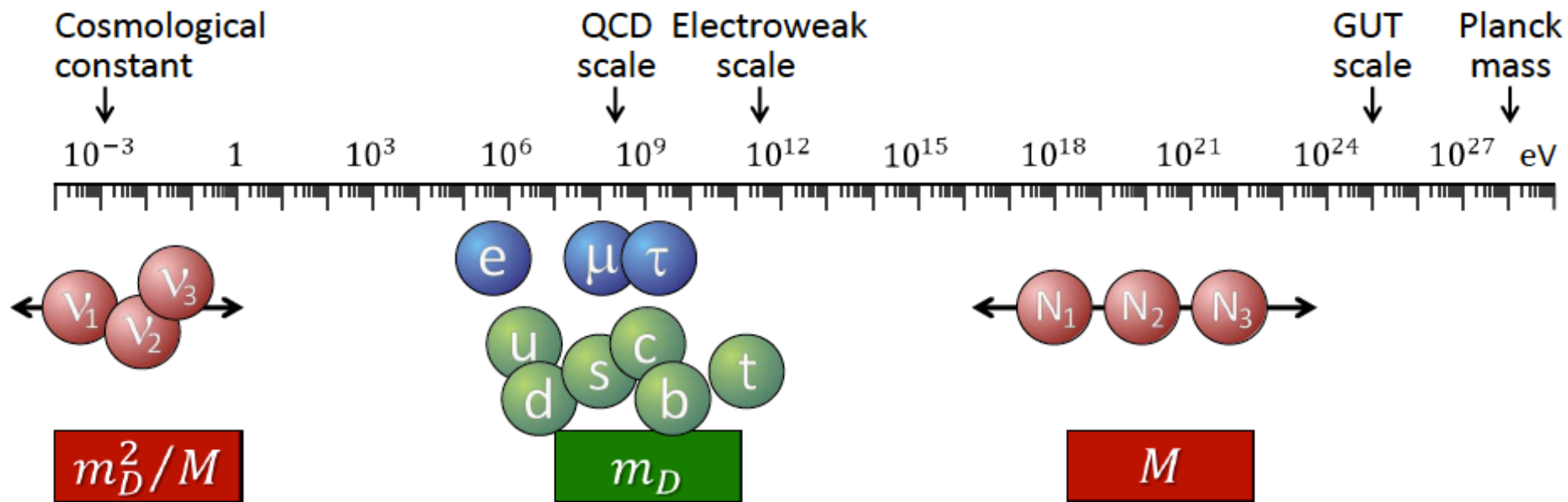

Mass matrix for one family of ordinary and heavy r.h. neutrinos

$$(\bar{\nu}_L, \bar{N}_R) \begin{pmatrix} 0 & m_D \\ m_D & M \end{pmatrix} \begin{pmatrix} \nu_L \\ N_R \end{pmatrix}$$

Diagonalization

$$(\bar{\nu}_L, \bar{N}_R) \begin{pmatrix} m_D^2/M & 0 \\ 0 & M \end{pmatrix} \begin{pmatrix} \nu_L \\ N_R \end{pmatrix}$$

One light and one heavy Majorana neutrino



Courtesy to George Raffelt